HOW TO CARE FOR YOUR NEW HOME

Revised 1.1.2024



INDEX

BATHROOMS	3-9	HOME EXTERIOR	34-53
1. Bath Fixtures		1. Brick	
2. Bath Tile and Grout		2. Exterior Doors	
3. Interior Caulking		3. Exterior Features	
4. Toilets		4. Garage Door	
ELECTRICAL	10-14	5. Gutters and Downspouts	
1. Circuit Breakers		6. Screens	
2. Electrical Troubleshooting		7. Siding	
3. GFCIs and AFCIs		8. Windows	
HEATING and COOLING	15-19	KITCHEN	54-62
1. Condensation Drain Line		1. Cabinets	
2. Fireplaces		2. Countertops	
3. Heating and Cooling System		3. Dishwasher	
4. Registers		4. Disposal	
5. Thermostat		5. Ranges and Ovens	
HOME INTERIOR	20-29	LANDSCAPING	63-68
1. Attic		1. Driveways, Walks, and Patios	
2. Exhaust Fans		2. Landscaping Grade	
3. Finishes		3. Sprinklers and Irrigation	
4. Locks and Doorknobs		PLUMBING	69-77
5. Main Shutoffs		1. Drains	
6. Smoke & Carbon Monoxide Detectors		2. Faucets	
7. Specialty Interior Doors		3. Pipes	
8. Walls and Ceilings		4. Shutoff Valves	
FLOORING	30-33	5. Water Heater	
1. Carpeting			
2. Ceramic Tile Floors			
3. Vinyl Floors			

BATHROOMS

Bath fixtures

The bathroom fixtures have protective surfaces that preserve their appearance and performance.

The bathtubs, sinks, showers, and toilets in your new home have protective surfaces. Keeping these surfaces clean and taking preventative measures to avoid damaging them will help preserve their look and functionality.

Care and maintenance

Follow these care and maintenance suggestions for your home's bath fixtures.

General care guidelines

Run exhaust fans or open windows to remove moisture from the bathroom.

Don't use sinks, bathtubs, showers, or other bath fixtures to hold paint cans, trash, or tools.

Do not place a ladder in tub or shower bases. The concentrated weight on the ladder legs may damage the base.

Cover plumbing fixtures when you're painting walls and ceilings.

Don't step into a bathtub or shower stall with shoes on. Shoe soles carry gritty particles that can scratch the surface.

Don't dispose of photographic developing solutions or other chemicals in sinks, tubs, or toilets. Development solutions or other chemicals may create stains that are extremely difficult to remove.

Mirrors

Clean mirrors with an ammonia-free cleaner. Using ammonia-based mirror cleaners will cause de-silvering along the edges of the mirrors.

Showers

Wipe the shower area dry after each use.

Clean the shower with an ordinary dishwashing detergent unless hard water minerals have been deposited.

If hard water minerals have been deposited, use a commercial glass cleaner containing ammonia or 1 tablespoon of household ammonia diluted in 1 quart of water.

Use Rain-X®* on glass to help reduce watermarks.
**Rain-X® is a registered trademark of SOPUS Products.*

Never use steel wool or scouring pads on the metal portion of shower enclosures. They remove the protective finish applied by the manufacturer and cause unsightly scratches.

Make sure water isn't escaping the shower enclosure. If it is escaping, make sure the door is completely closed.

Bathtubs

Clean bathtub with a foaming bath and tile cleaner to remove normal soil.

Never use any type of abrasive to clean the bathtub.

Don't use the tub spout as a support when getting in or out of the tub. Using the spout as a support may permanently damage it.

Fiberglass bathtubs and showers

Use special fiberglass cleaners, which are available at most supermarkets. Spray window cleaners also are effective.

For long-term protection, wax your fiberglass units with high-quality automobile wax immediately upon move-in and after each major cleaning.

Never use powdered cleansers or any type of abrasive on fiberglass tubs and showers.

Toilets

See *Toilets*.

Caulking

See *Interior caulking*.

Bath tile and grout

Ceramic tile's natural beauty adds a decorative touch to bath areas.

Care and maintenance

Ceramic tile is generally easy to maintain. Use the following suggestions to help keep your ceramic floors and walls looking new.

Floor and wall tile

Sweep or vacuum the floor areas to remove dust and debris before cleaning them.

Sweep or vacuum the floor tiles regularly to remove any abrasive particles that could damage the floor.

Clean the tile using a non-oil-based household cleaner that's compatible with cement grouts.

Wipe tile with a moist cloth, and wet mop it occasionally.

Clean and scrub tile floors with a cleaning solution using a cotton mop, cloth, sponge, or nonmetallic brush, and then rinse with clean water to remove the cleaning solution.

Avoid mildew buildup by cleaning tile with a cleaner specified to control mildew.

Use protective pads on furniture bottoms to help prevent scratching the tile.

Shower tiles

Clean ceramic shower tiles using an everyday, multipurpose spray cleaner that removes soap scum, hard water deposits, and mildew.



Refer to the manufacturer's recommendations for maintaining your tile.

Grout

Clean the grout used between ceramic tiles with a brush and a mild cleanser.

Use a grout sealer to make the grout more resistant to stains. This product can be purchased at most home care centers. Be aware that some sealers may discolor the grout.

Inspect for grout cracks frequently. Re-caulk and re-grout as soon as a crack is detected. When removing and replacing cracked grout, take it down to the subfloor or concrete to ensure that the new grout has adequate depth; otherwise, the new grout could re-crack or flake off.



Never use cleaners that contain acids or ammonia. Cleaners with acid will damage the grout and tile glazing, and ammonia cleaners might discolor the grout.

Interior caulking

Interior caulking is the elastic sealer around bathtubs, showers, countertop backsplashes, and other areas that need protection against water entry.

Interior caulking, which seals areas in your home and helps prevent moisture problems, will separate and deteriorate over the years.

If you don't maintain caulk on a consistent basis, moisture can work its way behind fixtures, damaging drywall and framing.

Care and maintenance

Follow these care and maintenance suggestions for your home's interior caulking.

To check caulk

Check and replace the caulk around areas that were caulked when your home was built. Look for separated and deteriorated caulk. The following are typical examples of places with caulk and the type of caulk to use:

Use silicone around showers, bathtubs, sinks, toilets, other plumbing fixtures and tub or shower to floor tile.

Use siliconized paintable latex caulk around window frames and door frames.

Use siliconized caulk between countertop and backsplashes, on ceramic walls, and joints where bathtub and shower bases meet floors.

Use siliconized paintable latex caulk on interior trim, interior millwork joints, and where countertops meet walls.

Use polyurethane based caulk between the sill plate and the foundation.



Don't use acrylic caulking over silicone caulking and vice versa. These two types of caulking do not bond properly with each other.

To reapply interior caulk

1. Remove the old caulk with a putty knife, scraper, or painter's tool.



2. Clean and dry the area that needs re-caulking. Caulk won't adhere correctly to a damp or dirty surface.



3. Apply the new caulk. Hold the caulking tube at a 45° angle from the surface. Push, rather than pull, the tube to drive the caulk into the gap. Pushing helps to fill the gap completely without trapping any air bubbles.

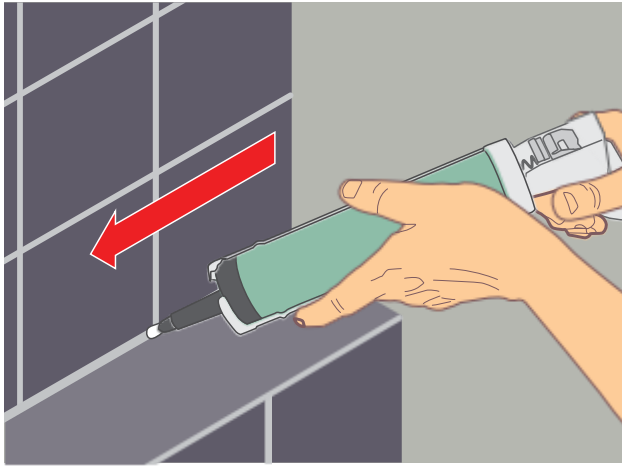

4. Twist the caulking tube and pull it back to break the caulk bead.

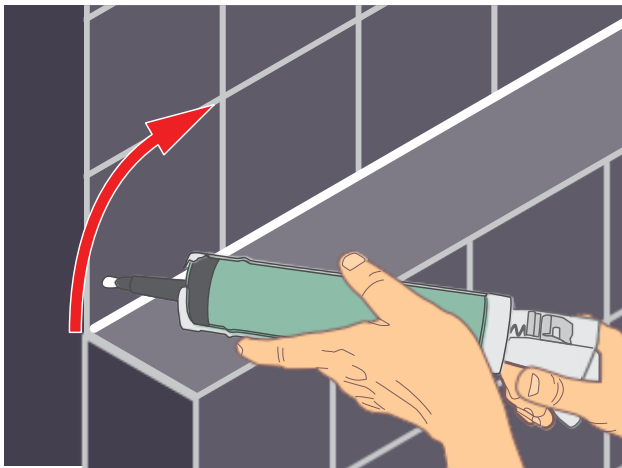

5. Run your finger along the joint to smooth and compress the caulk.

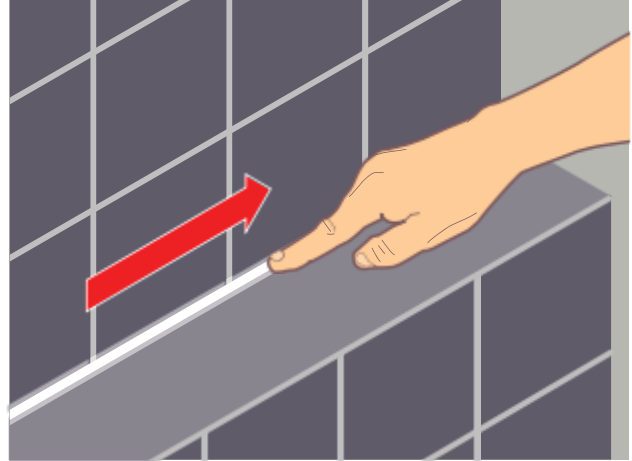

If you're using a caulking gun to apply the caulking, follow the directions on the tube to load and use the gun.

Toilets

Toilets are durable fixtures with parts and surfaces that require some maintenance. Toilets are made of vitreous china, a type of clay with a smoothed, glazed surface. The surface is durable but can be scratched with improper cleaning and use. The parts in the tank need replacing throughout the life of the home.

Toilet tank components: Filler Float type

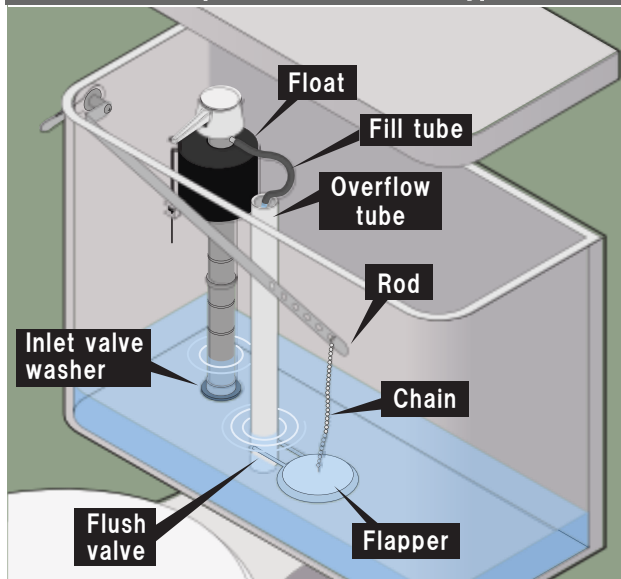

Toilet tank components: Ball Float type

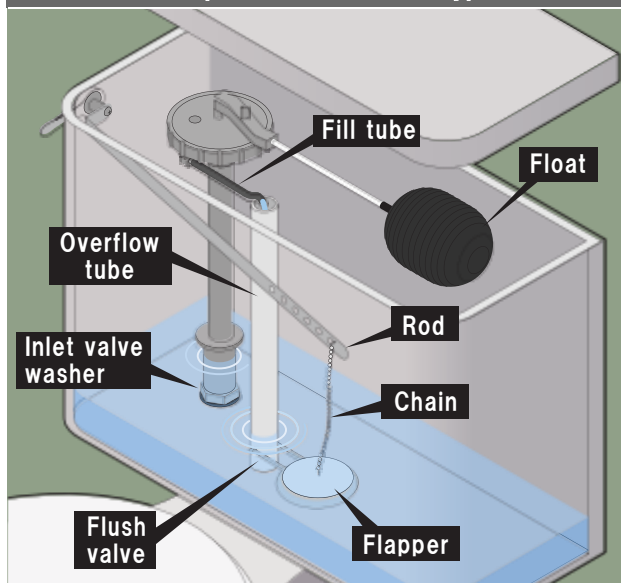

Care and maintenance

Follow these care and maintenance suggestions for your home's toilets.

To clean the toilet bowl

Use a commercial cleaner made especially for the toilet. Use it according to the manufacturer's instructions. Don't mix it or use it with household bleach or any other cleaning product.

Don't use suspended chlorine cleaning bars, chlorine tablets, or bluing pellets in your toilet; they can cause early deterioration of the rubber pieces located inside the toilet tank.

To protect the finish

Don't use commercial toilet cleaners for anything but the inside of the toilet bowl.

Don't use a strong abrasive to clean the outside of toilet; it may scratch the finish.

Don't clean the inside of the toilet tank; you risk damaging the interior parts.

Don't pour hot water into the toilet bowl or tank.

To prevent clogging

Pay special attention to the holes located under the bowl rim. If they aren't cleaned regularly, they can become clogged and cause the toilet to malfunction.

Never flush hair, grease, lint, diapers, rubbish, facial tissues, etc., down the toilet. These types of waste stop up the toilet and sanitary sewer lines.

To adjust the water level in the tank

Find the water level adjustment screw on top of the water control. Turn the screw clockwise to lower the water level and counterclockwise to raise it. The water level line is marked on the back of the tank.

To adjust the tank fill time

If your toilet has this feature, find the flow rate adjustment screw on top of the float rod assembly. Turn the screw clockwise to reduce the flow rate of the water and counterclockwise to increase it.



Toilet tank lids, which are also made of vitreous china, can be deceptively heavy, so be careful when lifting one off the tank before performing maintenance.

Repair

If the toilet doesn't flush

Adjust the float, which maintains the water level in the tank, so that the tank can store enough water for flushing.

Replace the flapper. The rubber flapper can deteriorate over time. You can find a new flapper at any hardware store. Follow the instructions on the package to replace it.

If the water tank appears to be leaking

If the tank appears to be leaking, it might be that condensation is forming on the outside of the tank and dripping to the floor.

If water leaks into the bowl

First, check the overflow tube. While holding the float, bend the rod closer to the bottom of the tank. Flush the toilet.

If water continues to leak into the bowl, you might need to replace the washer on the inlet valve.

If water leaks into the bowl, but isn't coming through the overflow tube, it's probably coming from the flush valve. Align the rods between the flush valve and the flushing handle so that the flush valve float drops straight down when the toilet is flushed.

If water leaks into the bowl from the tank, it could be caused by a warped flapper in the toilet tank. Check the flapper and replace if necessary.

Condensation on the water tank

Condensation can occur on the outside of the water tank and may look similar to a leak.

ELECTRICAL

Circuit breakers

Circuit breakers protect your home's electrical system from power failure.

The electrical wiring in your home is protected by circuit breakers. Circuit breakers, as a safety feature, will trip if there's an excessive load on a given circuit. Overloading a circuit when using too many appliances at one time, having a defective cord, or starting a large electric motor usually causes electrical failures.



The electrical panel box receives its electrical power from a cable called the electrical service entrance. Don't tamper with this cable.

Care and maintenance

Follow these care and maintenance suggestions for your home's electrical system.

Circuit breakers

If an outlet or light fixture fails to operate, check your circuit breaker panel before calling for electrical repairs. If the circuit breaker has automatically switched to OFF, either the circuit overloaded or a short circuit occurred.

If the circuit breaker has switched to OFF

1. Correct the cause of the circuit break before resetting the circuit breaker. Causes could be an excessive number of appliances or lamps plugged into any one outlet, frayed cords, and/or frayed connections.
2. Reset the breaker by pushing the switch all the way to OFF and then back to the ON position.

3. Repeat the steps above if any red shows near the breaker switch.

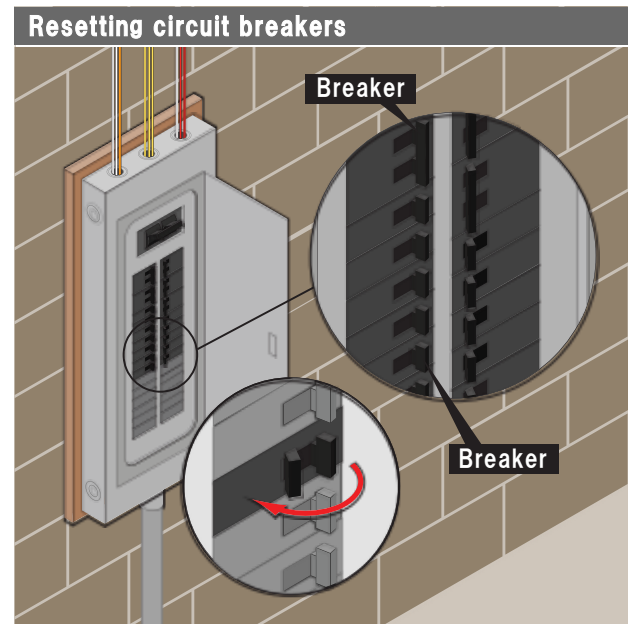

Excess dust on the circuit breakers may also cause them to trip. Use a can of compressed air to blow dust out of the breaker box.

If a circuit breaker trips frequently

Ordinarily, you can plug small appliances into any electrical outlet without overloading the circuit. However, if you use large appliances, such as electric space heaters, or several small appliances on the same circuit, you can overload the circuit and trip the breaker.

If you lose power in one area of your home:

Attempt to locate the cause of the failure before using the circuit breaker to restore the current.

If you can't locate the cause of the failure, call a state licensed electrician or Providence Homes.

You can reset a circuit breaker by flipping the appropriate switch all the way to OFF and then back to the ON position.

CAUTION

Never let anyone other than a licensed electrician repair or alter the wiring or electrical system in your home.

CAUTION

Some changes may require a permit. Poor electrical maintenance could lead to serious damage to your home and property or injury to you and your family.

Lighting fixtures

Your warranty doesn't cover any damages or short circuits caused by tampering with lighting fixtures, so don't attach, detach, or tamper with lighting fixtures. Hire a competent electrician to perform any work on fixtures.

CAUTION

Protect children from outlets and wiring. To protect small children, use outlet covers with childproof devices.

See also *Electrical troubleshooting*.

See also *GFCIs and AFCIs*.

Electrical troubleshooting

To save yourself time, money, and frustration, refer to this checklist before you report electrical problems.

If an outlet won't work

Make sure the wall switch isn't in the OFF position. If the wall switch is in the ON position, make sure the circuit breaker has not been tripped. If it has been tripped, try to locate the cause, and then reset it.

If a ceiling light or lamp won't turn on

Check the lightbulb. If the bulb is good, check the circuit breaker. Also, check for wall switches in the OFF position.

If the disposal won't operate

Push the reset button located on the disposal. If the disposal and dishwasher are designed to plug into an outlet, as opposed to being directly wired, make sure that the disposal and dishwasher are plugged into the right outlets. Also, check the circuit breaker.

If the oven won't heat

Check the owner's manual to make sure you're operating the time controls properly. Also, check the circuit breaker.

If the bath or utility exhaust fan won't run

If the fan doesn't make a humming noise, the problem is probably electrical, so call an approved electrician for service. If there's any movement or humming noise, the problem is probably with the fan unit, so call the manufacturer for service.

If an outlet sparks when you plug in an appliance

Make sure the appliance is off before plugging it in. If the outlet still sparks, try another outlet. If you get sparks from a second outlet, the problem is probably with the appliance cord.

If a switch or outlet is hot to the touch

Trip the appropriate circuit breaker immediately, and contact an approved electrician for service.



Sparks from wall switches or outlets should be checked by an approved electrician.

See also *Circuit breakers*.

GFCIs and AFCIs

Special circuit breakers in your home protect you and your family from fire, shock, and electrocution.

GFCIs

Ground Fault Circuit Interrupters (GFCIs) are located either in the electrical panel box or at outlets. They're a special type of breaker used for circuits that supply bathrooms, kitchens, laundry rooms, garages, and outdoor outlets.

GFCIs detect the slightest amount of unwanted electrical current flow, and trip immediately, cutting power to the circuit and protecting the person using the outlet. Without GFCI protection, a person could be shocked or electrocuted.

GFCIs are installed in your kitchen, bathrooms, garage, and at outdoor outlets—places that often get wet. If your power fails in just one of these areas, it probably means that the GFCI has been tripped.

GFCI circuit breakers are located on your circuit panel in the electrical panel box and have an extra button marked TEST. GFCI outlets look like ordinary outlets with the addition of two small buttons marked TEST and RESET.

AFCIs

In addition to GFCIs, some municipalities may require another type of electrical protection called Arc Fault Circuit Interrupters (AFCIs). AFCIs are designed to protect the electrical system from fire and are installed on circuits that service bedrooms.

AFCIs detect dangerous arcing in a circuit, extension cord, or appliance that could cause a fire. Arcing typically occurs because of loose connections along the circuit, cords pinched by furniture, and cables in contact with vibrating machinery. When arcing is detected, the AFCI trips immediately, cutting electricity to the circuit.

Care and maintenance

Follow these care and maintenance suggestions for your GFCIs and AFCIs.

If a GFCI or AFCI trips

GFCI outlets are highly sensitive to stray voltage and to moisture in the air. If an appliance that's plugged into a GFCI outlet short-circuits, the GFCI will trip, cutting off power to the related outlets.

On a GFCI outlet, push the RESET button on the center of the outlet to reset it. Reset a tripped GFCI or AFCI circuit breaker in the electrical panel box as you would reset a regular circuit breaker.



GFCI outlets aren't designed to carry the amperage for multiple hair dryers or major appliances, such as electric grills.

Testing GFCIs

A faulty GFCI can result in serious harm to you or your family if an accident occurs. Test each GFCI outlet once a month by following these steps:

1. Push the TEST button on the GFCI outlet. The GFCI should trip, resulting in power loss to the outlet.
2. Reset the GFCI, which should restore power to the outlet.
3. If the GFCI doesn't reset, try using a can of compressed air to blow out any excess dust. If it still doesn't reset or it doesn't trip, have it replaced by a professional electrician.

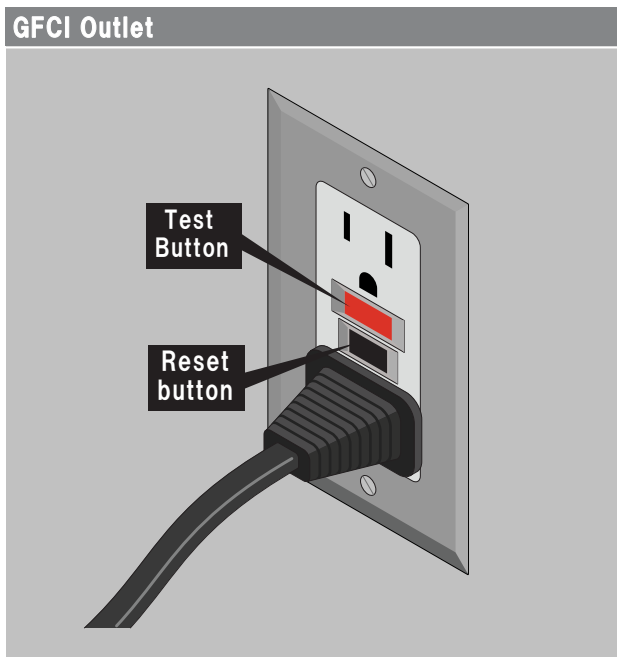

HEATING AND COOLING

Condensation drain line

The line that drains condensed moisture away from your heating and/or cooling unit needs periodic maintenance.

Air conditioning and high-efficiency heating units have a drain line that removes condensed moisture. When algae or debris block this line, water will back up into the drain pan. This pan is very shallow and can overflow, causing potential water damage to your home.

The primary drain line is built into the unit. Some units have a secondary drain line that can drain the unit if the first line becomes blocked. Frequently, a blocked drain line becomes a problem at the start of the cooling or heating season.

If your unit is located in the basement, the drain line runs to a floor drain.

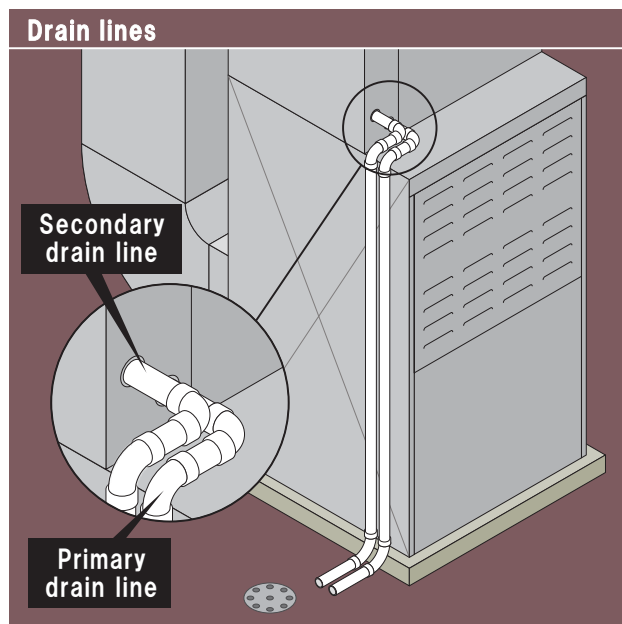

A semiannual preventative maintenance program is recommended. Semiannual maintenance is relatively inexpensive compared with the cost of repairing a leak.

Care and maintenance

Follow these care and maintenance suggestions for your home's condensation drain line.

To keep the unit draining properly

Have the primary drain line serviced by a professional to make sure it's draining correctly before the summer season each year.

If your unit has a secondary drain line, check to make sure it's draining correctly. See the unit manufacturer's instructions to check the secondary drain line.

Keep landscaping trimmed back from the outdoor condenser unit and condensation lines at all times. Check occasionally for debris in the outdoor condenser unit. First, turn off the air conditioner. Then check the outdoor unit for shrubbery, leaves, grass, or dirt impeding the flow of air from the unit. Use a water hose with an adjustable spray nozzle to remove obstructions. Also, check the base pan under the unit, and remove any debris that has accumulated.



When cleaning the condenser unit, don't apply too much water pressure; it could damage the coils.



The secondary line is usually placed over a doorway or window. If you see water dripping, this may indicate that there's a clog in the primary line.



Call for professional service if there's debris and dirt deep in the unit.

Fireplaces

Fireplaces add beauty and warmth to your home if you use them safely.

Using a wood-burning, gas, or electric fireplace properly and maintaining it correctly are important to your safety, as well as to the safety of your family and guests.

Care and maintenance

Follow the manufacturer's maintenance instructions, as well as these basic suggestions to care for your fireplace.

Gas and electric fireplaces

Conduct a checkup twice a year or after an extended period of disuse.

Never burn wood in a gas or electric fireplace.

Call a licensed contractor if you see arcing or call the gas company if you smell gas. Don't use the fireplace until after it's been repaired.

Heating and cooling system

Your home is equipped with a high efficiency heating and cooling system that has been engineered to operate effectively in all seasons to keep you and your family comfortable.

Furnace and air conditioner

The furnace generates heat by burning natural gas, or propane, then transfers the heat to the air and circulates it throughout your home.

The air conditioner is a split system. A cooled coil removes heat from the indoor air, and the outdoor fan unit disperses this heat into the outdoor air.

See also *Registers*.

Condensation drain line

See *Condensation drain line*.

Filter

The filter protects the unit from dust and debris. Never operate your unit without an air filter.

Care and maintenance

Follow these recommendations to keep your system running properly:

During the off-season, run the heating and cooling system at least once. It isn't good for the system to be out of operation for long periods of time.

Your outdoor air conditioning unit might have an external cartridge fuse or some other disconnect mechanism located in a small box next to the service panel or unit. If you experience a problem with this fuse, contact a licensed electrician to install a new cartridge.



Have a professional check all units according to your instruction manuals.



Have a professional inspect the furnace and the stack at least once a year before the heating season.



If you smell gas, call your gas company immediately.



On hot days, you can close drapes, blinds, and shutters to block heat. On cold, sunny days, you can open window coverings to speed heating.

Filter

Replace or clean the filter monthly for maximum efficiency. Clogged filters can cause the heating and cooling unit to malfunction.

The manufacturer's instruction manual for your system will tell you the location of the filter and how to clean and/or replace it. Make sure the unit is off before you clean or replace the filter. When replacing your filter, be sure to use a new filter of the exact same size and type.

Changing the air filter

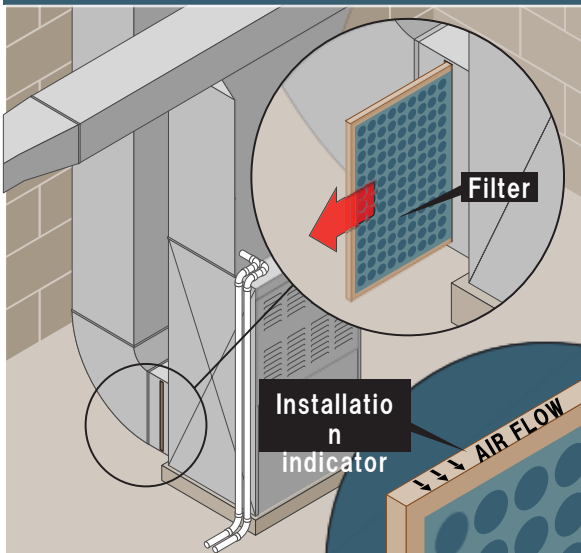

Insulation

Your home has the proper insulation for your climate. Inadequate heating and cooling is caused less often by inadequate insulation and more often by open doors, windows, fireplace flues, and clogged filters, as well as a lack of proper window coverings and the misuse of registers. If you feel the insulation may be inadequate, you may contact your Customer Service department.

Cooling coils

If your air conditioner freezes up, first check your filter to make sure it's not dirty. If the filter is clean, turn the system off until the ice melts. If the system continues to freeze up, call a certified technician.

Registers

Registers throughout your home help to regulate airflow and temperature.

At least one of the registers in your home is connected to an air return system that sends air back to the heating and cooling unit, where it's heated or cooled again and sent back out to registers throughout the home.

Care and maintenance

Follow these care and maintenance suggestions for your home's registers.

To adjust the registers

You can regulate individual room temperatures by adjusting the registers. By opening and closing the registers and dampers, you can adjust the amount of warm or cool air that enters a room.

Partially closing registers in rooms that get a lot of air forces more air into the rooms that don't get enough air. But don't close any registers completely.

If you close off registers

Even if you close off some registers, the system will continue working at the same pace; it can't sense that some of the registers are closed. In addition, all undesirable cold or hot air from the unoccupied room will mix with the rest of the air in the home.



You won't increase the comfort level or reduce energy costs by completely closing off registers in unoccupied rooms. This is because your system was designed to heat and cool a specific square footage of living space.

To get the most from the registers

Make sure the registers have plenty of clearance around them. Blocking registers with furniture and drapes can prevent much of the warmed or cooled air from distributing itself throughout the room. A blocked register, just like a clogged filter, will cause operational and maintenance problems for the heating or cooling unit.

If you can't avoid blocking registers, invest in some extenders that fit under or around furniture. Never block return intake registers. If stale air can't leave the room, fresh air won't come into the room.

To clean the registers

It's normal for the registers to get dusty as dust-laden air is pulled through them. Vacuum the registers periodically to remove dust and dirt.



Professional duct cleaning not only leaves your home with cleaner, healthier air, but it can also help your heating and cooling equipment to run more efficiently. Duct-cleaning contractors clean your registers, piping, and ductwork, as well as the furnace air filters and blower motor, removing dust and debris so they won't be moved through the indoor air.

Thermostat

The thermostat helps to maintain a comfortable interior temperature in your home.

The thermostat controls the heating and cooling systems in your home. It helps keep your home at an even temperature throughout, although individual room temperatures can vary.

Care and maintenance

Follow these care and maintenance suggestions for your home's thermostat.

To maintain a comfortable temperature

Set your thermostat to comfortable temperatures for you and your family. Recommended thermostat settings are 72°F for heating and 78°F for cooling.

Keep your thermostat settings constant to avoid energy-wasting fluctuations in temperature and to maximize energy efficiency.

Run the furnace recirculating fan more consistently to minimize temperature variations throughout your home. If you have a second floor, it's likely to be warmer than the lower levels.



Your thermostat might contain controls you can use to convert from the cooling system to the heating system and vice versa.

To activate new functions

Your thermostat has a five-minute time delay, which means there is a five-minute wait when switching functions. If you change functions during the five-minute delay, an additional five minutes will be added to the delay time. Wait the full time before expecting activation of the new function.



Overheating your home, especially in the first year, can cause excessive shrinkage in framing lumber, causing cosmetic damage inside the home.

To determine if you need service

According to the American Society of Heating, Refrigerating and Air-Conditioning Engineers (ASHRAE), your system should be able to produce an indoor temperature of 70°F for heating with an outside temperature or wind chill of -10°F and 78°F for cooling. If the outside temperature exceeds 95°F, it should be at least 15°F cooler indoors than it is outdoors.

HOME INTERIOR

Attic

It's important to maintain ventilation through the attic to prevent moisture buildup.

In most homes, you can access the attic by either an attic access ladder or steps installed in a garage or larger closet.

Attic ventilation

The sources of attic ventilation —louvers and vents— help prevent moisture buildup, reduce energy usage, and increase the life span of the roofing material. Louvers and vents keep out snow and wind-driven rain in normal conditions. Sometimes, rain and snow can enter through these openings when certain negative pressures exist.

Attic storage

Your attic shouldn't be used for storage or any other purpose.

CAUTION *Any damage resulting from the improper use of the attic space is the responsibility of the homeowner.*

Care and maintenance

Follow these care and maintenance suggestions for your home's attic.

To maintain sufficient ventilation through the attic

Keep the louvered openings unobstructed year-round. Louvers obstructed by debris or ice accumulation frequently lead to leaks.

Make sure your home's vents are clear of debris.

Check vents periodically to make sure they're secure and haven't come loose in high winds.

Inspect the attic once a year for water stains on the underside of the roof sheathing.

To prevent long-term damage to the attic

Check the attic insulation for moisture. If you find moisture, call for service immediately.



If you have loose-fill insulation, check to see if it has shifted due to major weather events. Use a plastic rake to move insulation from high spots to bald spots.



Have a qualified person inspect the attic for mildew, rot, and fungus. These problems indicate a high humidity level in the attic. Also, inspect for evidence of pests.

Exhaust fans

Exhaust fans provide ventilation to remove potentially damaging moisture from your home.

Showering, cooking, and other activities involving warm or boiling water produce a lot of moisture in your home. Moisture damages building materials and promotes mold growth.

Exhaust fans are installed in bathrooms and above the kitchen range. These fans play an important role in decreasing the level of moisture in your home.

Exhaust fans remove moisture before it causes problems. The fans also remove odors. To remove moisture from the air, run the exhaust fan at these times:

- During and after a shower or bath.
- While cooking.

In accordance with the Indiana Building Code, one bathroom exhaust fan in your home will run continuously. This exhaust fan will assist with circulation and moisture control throughout your home.

Care and maintenance

Follow these guidelines to keep your exhaust fans working:

Turn off the fan before performing any maintenance.

Make sure the fan is pulling air. To check, turn on the fan and hold a tissue near the grille; the tissue should hold tightly to the grille.

Clean the fan filter regularly to help maintain pulling power.

Clean the fan blades as needed. First unplug the fan, and then wipe the blades with a damp cloth.

Use a can of compressed air to blow dust out of the fan.



Make sure you unplug electrical appliances before you clean them.

See also **Ranges, cooktops, and ovens.**

Finishes

The finishes in your kitchen and bath are durable and will remain beautiful with proper care.

Enamel

Enamels are made from tile, porcelain, or vitreous china. These surfaces are hard, but they can be scratched and chipped with misuse, such as by a blow with a heavy object or by cleaning with abrasive cleansers.

Stainless steel

Stainless steel fixtures generally resist staining. They need a thorough scrubbing only occasionally. With maintenance, a stainless steel finish can last many years. Small scratches that do occur over time will usually blend in with the overall finish.

Chrome, nickel, and brass

Chrome is a hard, durable, and scratch-resistant finish. Nickel, which looks similar to chrome except with a warmer undertone, is softer and scratches more easily. Brass, like nickel, also scratches easily. Brass fixtures are usually treated with a clear protective coating to make the surface more durable.

Care and maintenance

Follow these care and maintenance suggestions for the finishes in your home's kitchen and bath.

Enamel

When washing dishes

Be careful with metal utensils, sharp utensils, pots and pans, etc. Scraping or banging metal utensils in a sink gradually scratches and dulls the enamel, making it susceptible to stains that become increasingly difficult to remove. A blow from a heavy or sharp object will chip the surface.

When cleaning

Don't use strong abrasive cleansers. Shiny new fixtures can be dulled or stained in a short period of time with strong abrasive cleansers. Improper cleaning can chip, scratch, and stain the enamel.



Most household cleaners are mildly abrasive, but when used with plenty of water, some aren't harmful. You can use baking soda or Bon Ami® Powder (not Bon Ami®* Cleanser), which are nonabrasive, to clean enamel.*

*Bon Ami® is a registered trademark of the Bon Ami Company.



To fill chips in porcelain finishes, a bottle of liquid porcelain from your local hardware store is a simple, inexpensive remedy. Follow the product directions carefully. Apply a second coat if necessary to fill a deep chip.

Stainless steel

Clean a stainless steel finish with warm water and a nonabrasive cleanser or a commercial stainless steel cleanser. Dry completely after cleaning.

Clean a stainless steel sink occasionally by filling it full with a 50/50 solution of water and bleach. Let the solution stand for 15 minutes. Drain the solution while washing the sides and bottom of the sink. Rinse thoroughly.

Rinse a stainless steel sink after each use to remove chloride residue found in most soaps, detergents, and cleansers.

Scrub a stainless steel sink once a week; this will help keep the finish looking lustrous.

Don't allow soaps, salts, or water to dry on the finish. Wipe the surface dry after each use.

Be careful when washing dishes in the sink. Stainless steel sinks will dent when they receive a strong impact.

Don't use steel wool pads. They can remove the finish. Don't use a stainless steel sink as a chopping block or cutting board. The knives will scratch the sink's finish, and the stainless steel will dull your knives.



Wet sponges, cloths, and cleaning pads left on the sink surface can lead to discoloration, pitting, and rust.

Chrome, nickel, and brass

Don't use an abrasive cleaner, which may scratch the surface and remove the finish.

Clean chrome finishes with a soft cloth and a nonabrasive wax polish. Otherwise, chrome needs very little maintenance.

Clean nickel and brass with a nonabrasive cleaner, and then buff them with a soft cloth.

Wipe water spots with a soft cloth. Don't allow water to dry on any finishes.



There are many finishes in your home. Refer to the manufacturer's recommendations for the most up-to-date care and maintenance information.

Locks and doorknobs

Privacy and security locks and doorknobs are easy to maintain.

Care and maintenance

Follow these care and maintenance suggestions for your home's locks and doorknobs.

To keep the doorknobs working

Hardware for passage doors can work loose through use. Tighten screws as required.

When opening and closing a door, try to avoid excessive play on the doorknob escutcheon plate.

If a doorknob or lock becomes inoperative, call a locksmith.

HOMEOWNER TIP *Have duplicate keys made and keep them in convenient places so you'll have access if you get locked out. When you take a vacation, it's a good idea to leave a key with a neighbor for use in the event of an emergency.*

HOMEOWNER TIP *Keep the release pins or keys for interior doors in a handy place. They're used to unlock an interior door from the outside.*

To minimize wear and tarnishing

Clean the hardware on a regular basis per the manufacturer's instructions.

Most exterior hardware is finished with a sealant. Often this sealant can wear, and the hardware will tarnish.

Tighten any exposed hardware screws.

Make sure all hardware works smoothly.

Lubricate exterior locks with a graphite product. Don't lubricate with oils, such as WD-40®-type lubes, as they can freeze in colder climates and foul the lock pins in any climate.

*WD-40® is a registered trademark of the WD-40 Company.

HOMEOWNER TIP *Keys used during the construction of your new home won't operate the locks after you have closed on the property.*

Main shutoffs

Your home has main shutoffs to your plumbing and electricity—the main water shutoff valve and the master circuit breaker.

Main water shutoff

The main water shutoff valve shuts off the water supply for the entire house. It can be found where the main water supply from the street enters either through the foundation wall (in a home with a basement) or through the slab (in a home without a basement).

See also *Shutoff valves*.

Main electrical shutoff

Every home has a master circuit breaker and smaller circuit breakers, which are located in the electrical panel box. When the master breaker trips, the electricity in your home is cut off. You can reset circuit breakers by pushing the switch all the way to OFF and then back to the ON position.

See also *Circuit breakers*.

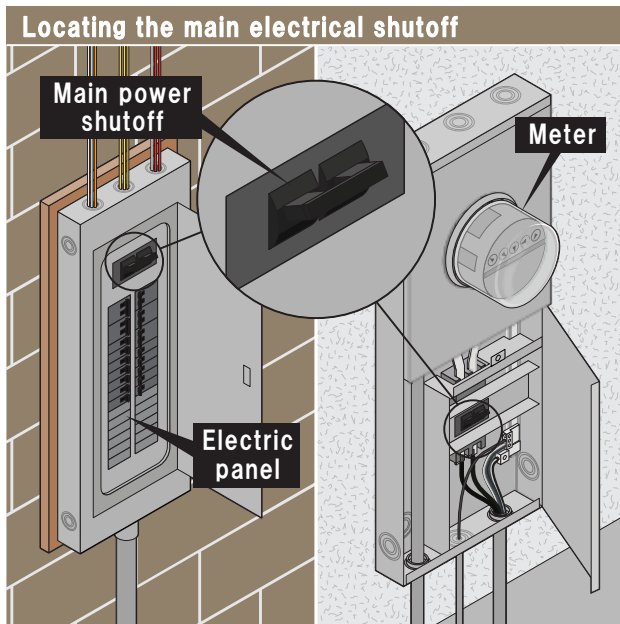

Read and follow all warnings on the main shutoffs.

Smoke and carbon monoxide detectors

The smoke and carbon monoxide (CO) detectors installed in your home are essential to your health and fire safety, so make sure they're working to protect you and your family.

With proper maintenance, smoke and CO detectors can help to protect you and your family in fire emergencies. Each unit can detect both smoke and carbon monoxide. The detectors are hardwired to your electrical system. They also include battery backups.

Care and maintenance

Follow these care and maintenance suggestions for your home's smoke and CO detectors.

To test the detectors

Check your smoke and CO detectors every month by pushing the test button on each one. The alarm should sound when you push the test button. If you hear only a chirp or nothing at all, you need to replace the battery.

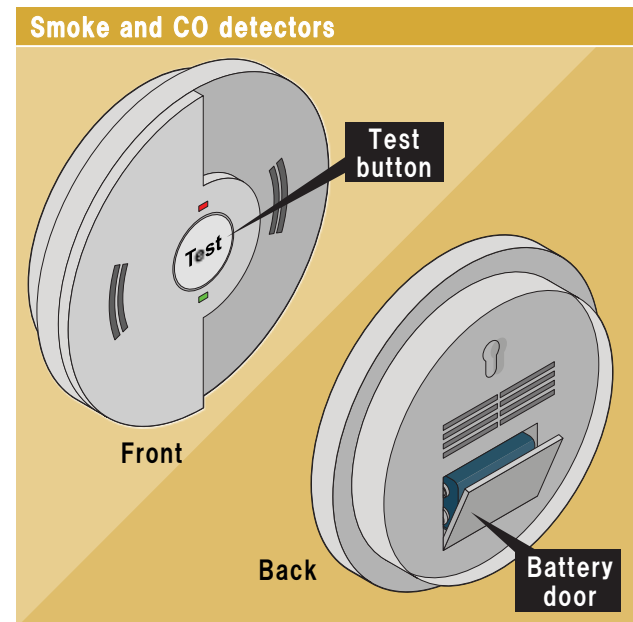

Read the manufacturer's instructions to find out exactly how to test your detector.

To keep the detectors working correctly

For your safety, it's important to keep the detectors clean and in proper working condition. Dust can make a detector less sensitive to heat and smoke and can cause it to give a false alarm. Remove dust by taking the top off a detector and vacuuming the inside using the drapery-cleaning attachment of a vacuum cleaner. You can also use a can of compressed air to blow out any dust.

The backup battery

Each smoke and CO detector is hardwired to your electrical system. Each detector also includes a 9-volt battery backup so that if the electricity is cut off, the detector will still work. When you need to replace the battery, a detector will chirp. Keep replacement batteries on hand.

Follow these steps to change the battery. If these steps aren't followed, a false alarm may sound and continue chirping.

1. Disconnect the hardwire harness.
2. Remove the old battery.
3. Press the test button to discharge any latent energy..
4. Install the new battery.
5. Reconnect the wire harness.

HOMEOWNER TIP *Replace all smoke and CO detector batteries each year during the change to daylight saving time. This will help keep your detectors fully operational.*

HOMEOWNER TIP *In most homes, when one smoke or CO detector isn't working properly, all of the detectors will chirp. To find the detector that isn't working properly, look for the one with the red light indicator.*

Specialty interior doors

Bifold, bypass, and sliding pocket doors are convenient and conserve space in your home. The mechanics of these doors are more complicated than those of a hinged door. When operating these doors, gentleness is important, so don't apply up or down pressure to open or close them.

Bifold doors

Bifold doors are frequently used for closets, laundry rooms, and pantries. A single bifold door is made up of two door segments that fold into each other when slid along the track. To open this type of door, gently pull the door toward you, and the door will open itself.

Bypass doors

Bypass doors, also known as sliding doors, are two door segments that glide on a track, bypassing each other. Your closet and shower doors may be bypass doors. To open this type of door, gently push the movable segment in the appropriate direction, and the door will open itself.

Sliding pocket doors

Sliding pocket doors slide into the wall, helping to save space in any room. These doors are usually used as room dividers, such as between a dining room and a kitchen, or in an area with limited space. To open this type of door, gently push a sliding pocket door in the direction the door moves, and the door will open itself.

Care and maintenance

Bifold, bypass, and sliding pocket doors are installed in matched sets. If you remove the doors for any reason, be sure to put each section back in its original position. The following guidelines will help you care for these interior doors.

To maintain bifold doors

If these doors become difficult to operate or jump from their tracks, find their adjustment areas, which are located on the rear sides of the doors. Follow the manufacturer's instructions to adjust the doors.

Check the top corner brackets for loosening of the set screws.

Avoid getting paint on the top spring-loaded pins during any repainting.

To maintain bypass doors

If these doors become difficult to operate or jump from their tracks, find their adjustment areas, which are located on the rear sides of the doors. Follow the manufacturer's instructions to adjust the doors.

Avoid getting paint on the door track or rollers during any repainting.

Be careful when opening bypass doors. Bumping the doors forcefully against the door-opening returns can jump the doors off the top tracks.

To maintain sliding pocket doors

If these doors become difficult to operate, it's likely they have jumped from their tracks. Check the rollers to see if they're broken or off the track. Follow the manufacturer's instructions to adjust the doors.

If a roller is loose, simply tighten or replace the screws. If a roller is broken, you'll have to replace it.

Don't drive nails into the pocket area of a sliding door. The protruding nail can damage the surface of the door. Use adhesive-type hangers for pictures on walls that contain a sliding pocket door.

Walls and ceilings

Your home has been built with quality walls and ceilings.

Care and maintenance

Follow these care and maintenance suggestions for your home's walls and ceilings.

Interior walls and ceilings

The interior walls and ceilings in your home have been built with quality drywall and paint products. They'll last for the life of your home if you care for them properly.

Remove most spots by gently cleaning with a mild soap. Don't scrub painted walls. This may stain flat paint, which stains easily.

Check your walls and ceilings for signs of condensation and/or mold growth; if you detect any, call for service immediately.

Don't wash newly painted surfaces for the first few months; the paint needs time to dry and set.

Keep the filters for your heating and cooling units clean, use the exhaust fans over your range and in the bathrooms, and vacuum dust promptly as it collects to help avoid having to repaint frequently.



It is common for some sound to transfer between neighboring units.



Don't overload closet rods.



Ceiling outlets, which are sometimes installed in garages and attics, typically can't support light fixtures or ceiling fans that weigh more than 50 pounds.



Most latex paints can be stored for two years without risking deterioration; however, exposure to extreme heat or cold may shorten the paint's life span. Avoid using latex paint when the wall or ceiling surface temperature is above 90°F or below 45°F.



Ceiling drywall is not designed to support any weight. Locate a ceiling joist in which to attach hardware for heavy hanging plants, lamps, and macramé.

To repair the surface

As new homes go through a normal shrinkage process, minor cracks, and possibly nail or screw pops, will appear. Don't make any repairs in the drywall until you're ready to repaint the room.

Cracks

Fill any cracks with an elastomeric caulking, which is available from any paint or hardware store.

Indentations

Fill indentations in the surface of drywall with two or three applications of the joint compound used for drywall taping, which is available at any hardware store. Smooth out the compound with fine sandpaper and repaint the area.

Screw or nail pops

A screw or nail pop looks like a small dent (concave) or bump (convex) on the surface of the wall. It occurs when this common drywall issue can occur with both nails *and* screws, the two types of fasteners used in drywall installations. Happily, popped nails and screws don't diminish a wall's strength—they're just unattractive.

To fix a screw or nail pop

To fix a screw or nail pop, follow these steps:

Use a hammer to drive the popped nail back into the wall. Then, drive a new nail into the wall, lapping the head of the new nail over the head of the old one.

If your drywall has screws instead of nails, remove the popped screw and screw it into the drywall 1" away from its previous location.

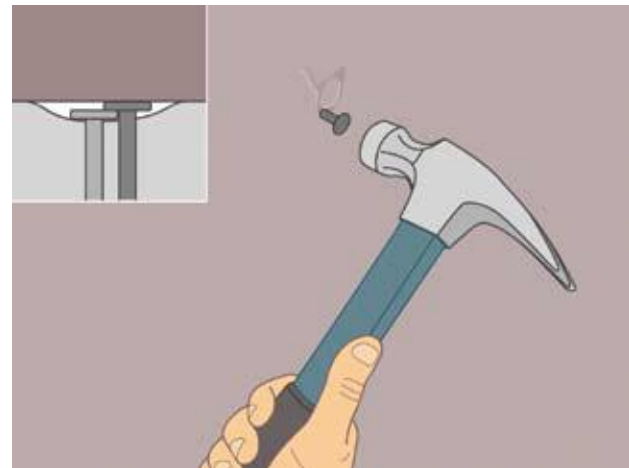

Make sure the nails (or screws) are set into the drywall just enough where they aren't protruding from the surface. A good way to check is to run a putty knife over the nails (or screws) and listen for a clicking sound.

2. Apply a spackling compound over the nails (or screws) using a putty knife; follow the spackle manufacturer's instructions. Make sure you spread the paste evenly across the surface. Spackle is available from any paint store or home care center.



3. Smooth out the surface with fine sandpaper once the spackle has dried. The wall should be smooth to the touch.



4. Use a cloth to wipe away any dust from sanding.



5. Redecorate the surface using paint, wallpaper, or other wall décor.



FLOORING

Carpeting

Your attractive, durable carpeting will look great for years with regular cleaning and maintenance.

Care and maintenance

Follow these care and maintenance suggestions for your home's carpeting.

To clean the carpeting

Vacuum carpeting at least once a week. Vacuuming is especially important for some of the denser shear and shag patterns.

Have your carpeting cleaned professionally at least once a year to remove deep-down dirt and stubborn stains.

Dry wet carpeting immediately to avoid delamination.

To remove spots, use the manufacturer's recommended cleaning products and follow the instructions for spot removal.



If carpeting gets saturated, call a certified remediation company.

To prevent staining

Always attack stains immediately. Even half an hour after the accident can be too late.

Seek the advice of a carpeting expert to get the best stain or spot remover for your style of carpet. A number of good-quality stain and spot removers are available.



In cases of severe staining or spotting on carpeting, don't hesitate to call a professional. The small expense will pay off in longer carpet beauty and service.

To preserve the carpeting

Protect your carpeting from direct sunlight, as it can cause carpeting to age.

Avoid excessive pile crushing by moving heavy furniture periodically.

Check for loose threads. Trim any loose threads so they don't unravel.



Loose carpeting can be re-stretched, and delaminating seams can be repaired.

To protect your furniture

If your carpeting becomes wet or saturated, create a barrier between the wet carpeting and the bottoms of all wood furniture. Aluminum foil or plastic coasters work well as barriers.

For more information about carpeting, visit the manufacturer's website.

Ceramic tile floors

Ceramic tile adds a beautiful decorative touch to your home and is easy to clean and maintain.

Care and maintenance

Ceramic tile is generally easy to maintain. Follow these care and maintenance suggestions to help keep it looking new.

General maintenance

Sweep or vacuum the floor areas to remove dust and debris before cleaning them.

Use protective mats at all exterior-to-interior entrances to tile floors.

Use protective pads on your furniture bottoms to help prevent scratching the tile.

To care for the grout

Clean the grout used between ceramic tiles with a brush and a mild cleanser.

Use a grout sealer annually to make the grout more resistant to stains. This product can be purchased at most home care centers. Grout sealer can discolor the grout, though, and doesn't waterproof it.

To care for the tile

Sweep or vacuum the floor tiles regularly to remove any abrasive particles that could damage the floor.

Wipe tile with a moist cloth, and wet mop it occasionally.

Clean the tile using a non-oil-based household cleaner that's compatible with cement grouts.

Clean and scrub tile floors with a cleaning solution using a cotton mop, cloth, sponge, or nonmetallic brush, and then rinse with clean water to remove the cleaning solution.



Refer to the manufacturer's recommendations for maintaining your tile.



Never use a vacuum with a beater bar or power rotary brush head; these will damage the surface of the tile.



Never use cleaners that contain acids or ammonia. Cleaners with acid will damage the grout and tile glazing, and ammonia cleaners might discolor the grout.

Luxury Vinyl Plank and Luxury Vinyl Tile

The luxury vinyl flooring in your home is made of wear-resistant materials that are easy to clean and maintain.

Luxury vinyl floors are very durable. The clear, nonporous wear layer keeps spots and spills out while sealing in your floor's natural beauty.

Care and maintenance

Follow these care and maintenance suggestions for your home's luxury vinyl flooring.

General maintenance

Use the manufacturer's recommended maintenance products and follow the instructions to maintain the flooring.

Remove spills immediately.

Never use a vacuum with a beater bar, as it can damage the floor.

Equip all furniture and appliances with glides or felt furniture pads to protect the floor and replace when worn or dirty to prevent scratches.

Place rug at the entrances to rooms to reduce dirt and grime being tracked in and at sinks and high traffic areas. Rugs must be made of a breathable material to prevent moisture entrapment. We recommend using a breathable underlay; mesh or grid patterns are best. Do not use rugs with solid rubber or vinyl backings as this may damage the finish.

Avoid using rolling casters, as they can damage the floor.

Don't drag heavy items, such as furniture, as they can cause scuffs and tears.

To clean luxury vinyl flooring

Dust or vacuum your floors. Mop using a mild cleaning solution, such as liquid dish soap weekly.

Don't use detergents, abrasives, paste wax, solvent-based polishes, or any "mop and shine" products on the flooring.

Remove loose dirt with a broom, dust mop, or vacuum daily.

Wipe up spills immediately. If a spill dries, remove it with a damp sponge, cloth, or mop.

Damp mop occasionally to prolong the period between cleanings.



High heel shoes or furniture legs without floor protectors will cause damage to flooring.



If possible, limit the amount of direct sunlight by using curtains or blinds in areas exposed to high UV rays.



Don't use abrasive cleaners or bleaches on vinyl floors.



Use care when moving heavy appliances, furniture, or chairs to avoid damaging the flooring.



***NEVER** use a steam mop or wet-mop as standing water may cause permanent damage and the heat from the steam mop may dull the finish*

Laminate Flooring

The laminate flooring in your home is engineered to be easily maintained, while providing years of durable service.

Care and maintenance

Follow these care and maintenance suggestions for your home's laminate flooring.

General maintenance

Use the manufacturer's recommended maintenance products and follow the instructions to maintain the flooring.

Remove spills immediately.

Never use a vacuum with a beater bar, as it can damage the floor.

Do not use power scrubbers to clean your floors.

Dust mop as a primary cleaning method. **DO NOT** flood mop. To damp mop, use a well wrung out mop. Always keep standing and excessive moisture off the floor.

A residential steam mop may be used, provided the steam is applied to a microfiber pad and not directly to the floor. Make sure the temperature is set to the appropriate temperature for laminate floors. Steam mop in the direction of the planks.

Felt floor protectors are recommended under furniture.

Keep pet nails trimmed to minimize scratches.

Replace rubber casters with soft neoprene casters and routinely clean to remove grit.

Protect from spiked heels and athletic shoes.

Protect from direct sunlight.

Do not use rubber lined rugs or mats as they may stain.

For more information about vinyl and laminate flooring, visit the manufacturer's website.

HOME EXTERIOR

Brick

The exterior brick on your home contributes curb appeal and is extremely durable.

Brick, made from fired clay, offers fire resistance, low maintenance, high aesthetic value, and energy conservation.

Care and maintenance

There's very little you'll ever have to do to maintain your brick exterior over the years. Follow these suggestions for minor maintenance.

General maintenance

Follow these maintenance suggestions for exterior brick:

Remove any plants or vines growing on brick walls with a commercial weed killer. Be sure to read the weed killer's instructions first. Plants or vines hold in moisture and may cause damage to your home's exterior.

Check the caulking between the brick and the windows and doors once a year. Remove and re-caulk as needed with a Polyurethane based caulk.

Make sure nothing obstructs the weep holes, which keep moisture from being trapped between the drainage plane and the brick. Check once a year.

Check mortar joints every three years for deterioration.

Check the transition from brick to stucco for cracking once a year. If there are cracks, caulk and paint them as necessary.

See also [Exterior caulking](#).

To clean the brick

There are general practices for cleaning brick. These general practices are applicable to many types of cleaning solutions and many types of brick. However, they may not be effective across the board. For example, the color and texture of the brick, as well as the substance staining the brick, can influence the effectiveness of the cleaning practice. As a result, it's always best to gather as much information about your home's brick exterior beforehand and consult a brick manufacturer for advice. Overall, just be careful to select a cleaning product that's suitable for your brick and to follow the cleaner manufacturer's instructions.

In general, to clean brick, follow these steps.

1. Choose the proper cleaning solution based on the type of brick and the substance staining its surface.

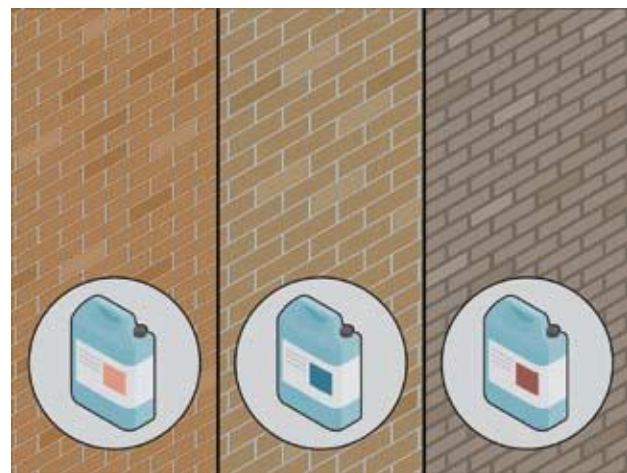

2. Protect any objects nearby, such as plants, windows, and doors, if necessary. Certain cleaning solutions can damage them.



3. Test the brick's absorption rate. Wet a small area of brick using a garden hose. If the brick turns darker at once, you should clean only a small area of the brick face at a time. If it doesn't, clean up to 100 square feet at a time.



HOMEOWNER TIP *It's important to test the brick's absorption rate. Knowing this information beforehand allows you to estimate how large of an area you can clean at one time.*

4. Saturate the brick area to be cleaned using clean water from a garden hose. Spray the area from the top down.



HOMEOWNER TIP *Brick must be saturated with water before it's cleaned. If the cleaning solution is absorbed by the brick, it can leave stains behind on the surface. By saturating the wall with water beforehand, the brick is unable to absorb the cleaning solution, thereby preventing any unattractive stains from appearing after the brick is rinsed and allowed to dry.*

5. Saturate any brick that's below the area you're cleaning. Make sure to keep this brick saturated until you've rinsed away the cleaning solution from the brick above. By taking this step, you're helping to prevent streaking and the absorption of runoff that's come from above.

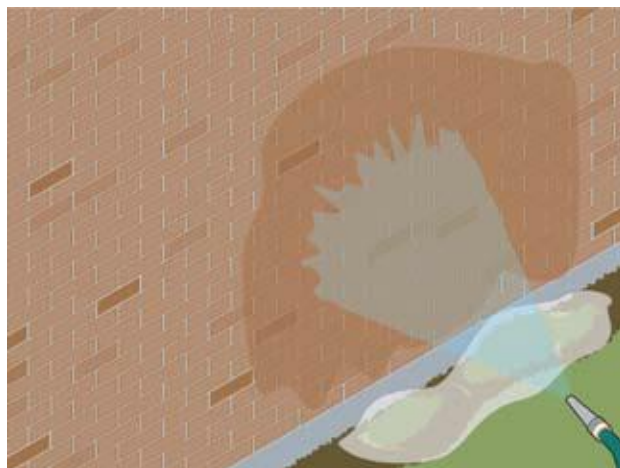

6. Apply the cleaning solution to the brick.

The exact method depends upon the cleaning solution you've chosen. If it's a commercial cleaning solution, make sure to follow the manufacturer's instructions.



7. Rinse the brick face thoroughly after cleaning.

Use large amounts of clean water, moving from the top to the bottom of the wall. Make sure all of the cleaning solution is washed away, as any left behind can stain the brick's surface.



To clean mold off the brick

Mildew can grow on areas of the brick that the sun doesn't reach. Periodically, clean these areas with a brick-cleaning detergent, which you can purchase at most hardware stores. Check the manufacturer's instructions to see which chemicals are best for your brick exterior.

CAUTION ▶ *Be careful when using a pressure washer, since this may damage the brick surface if the wrong pressure is applied.*

To remove stains

You can remove most stains on exterior brick with a stiff brush and a solution of household detergent and water. Some stains, such as smoke, paint, and oil, require special treatments. Use the manufacturer's recommended cleaning product and follow the instructions to remove the stains.

CAUTION ▶ *Protect any areas of brick that don't need cleaning.*

If your home is part of a Homeowner's Association (HOA)

Check with your HOA regarding maintenance and be familiar with all HOA documentation.

For more information about brick, visit the manufacturer's website.

Exterior caulking

Exterior caulk is the elastic sealer around window and door frames that helps seal air leaks and prevent water entry around these openings.

The caulk will separate and deteriorate over the life of the home. If you don't check the caulking and remove and reapply it on a consistent basis, moisture can work its way behind wood trim or siding and possibly cause serious rotting.

Leaks around exterior doors and windows can result if separated or deteriorated caulk goes unnoticed for any length of time.

Care and maintenance

Follow these care and maintenance suggestions for your home's exterior caulking.

To check caulk

Check for separated and deteriorated caulk around the exterior of your home about one to two times a year. The following are typical places that need caulk:

Between the foundation and the siding.

Around window frames and door frames.

Around any object protruding from an exterior wall, such as vents, outlets, pipes, and faucets.

Around any object protruding from the roof, such as chimneys, vents, and skylights.

At the corners and angles between siding materials.



Use a polyurethane-based caulk to do any repairs.



Don't use acrylic caulking over silicone caulking and vice versa. These two types of caulking do not bond properly with each other.



Don't apply exterior caulk in cold weather. Caulk is best applied when the outdoor temperature is between 50°F and 70°F.

To reapply exterior caulk

1. Remove the old caulk with a putty knife, scraper, or painter's tool.

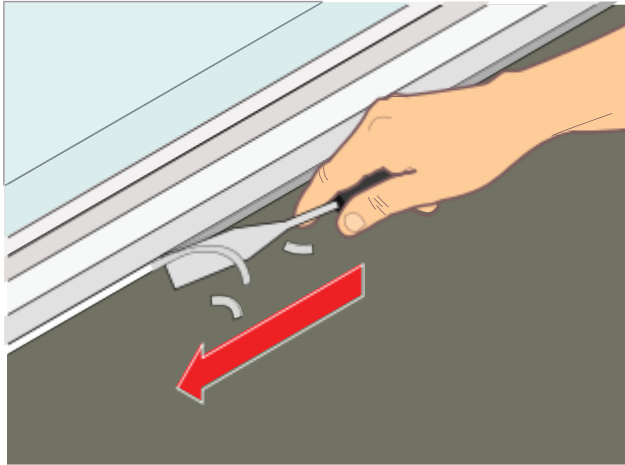

2. Clean and dry the area that needs re-caulking. Caulk won't adhere correctly to a damp or dirty surface.



3. Apply the new caulk. Hold the caulking tube at a 45° angle from the surface and push, rather than pull, the tube to drive the caulk into the gap. Pushing helps to fill the gap completely without trapping any air bubbles.

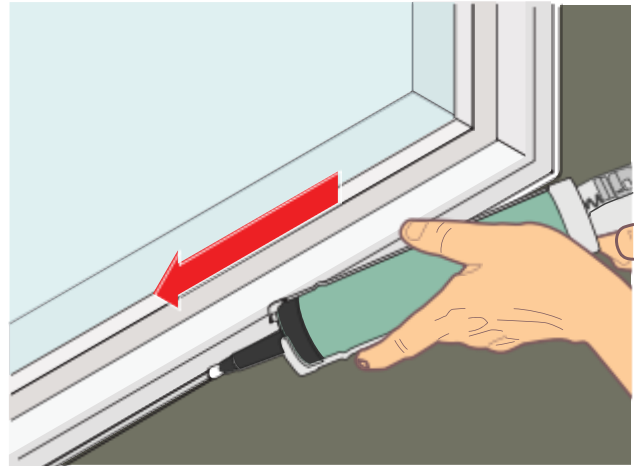

4. Twist the caulking tube and pull it back to break the caulk bead.



Check the seal base of the door for rips, tears, and excess wear.

Check the screws on the threshold. Tighten them if they stick up, so they don't damage the door seal.

If you see the black residue of iron around door hinges:

You can remove the iron residue with a magnet behind a cloth or by lightly wiping with a damp sponge or clean cloth. This residue is a by-product of the friction created when the hinges open and close.

Sliding glass doors

Always keep the tracks clean of debris.

Apply a very small amount of oil periodically at both the bottom of the door and at the lock mechanism.

Apply silicone lubricant to the tracks. It's important to take special care of the tracks of sliding glass doors.

Make adjustments to the threshold of the door if it doesn't slide properly, drags on the sill, or is difficult to open.



Check the manufacturer's instructions to find out how to adjust a door. Also, check the manufacturer's instructions if the door fails to latch or slide smoothly.

If your home is part of a Homeowner's Association (HOA)

Check with your HOA regarding maintenance, and be familiar with all HOA documentation.

Exterior features

The light fixtures and other features on your home's exterior need maintenance to keep them looking great and to prevent leaks and other problems.

Care and maintenance

Follow these care and maintenance suggestions for your home's exterior features.

Light fixtures

Avoid leaving porch lights on all night; the light will attract bugs, which will enter your home when you open the door. Use yellow lightbulbs in yard light fixtures. Insects are less attracted to yellow light.

Check exterior light fixtures for defective bulbs once a week.

Clean light fixtures with a mild soap detergent. Before cleaning, cut the power to the light fixtures by flipping the circuit breakers to OFF. After cleaning, allow the fixtures to dry thoroughly, and then reset the breakers to ON.

Inspect and repair any holes around the light fixtures with an elastomeric caulk.



Before cleaning a brass fixture, make sure the fixture is actual brass and not simply brass-finished. A brass-cleaning product can damage a brass finish.

For more information about exterior lighting, visit the manufacturer's website.

See also *Exterior caulking*.

Dryer vent

Make sure your dryer vent isn't blocked.

Remove lint from the dryer's lint filter after every load. Remove any accumulated lint from the exhaust duct running between the back of your dryer and the dryer vent once a year.

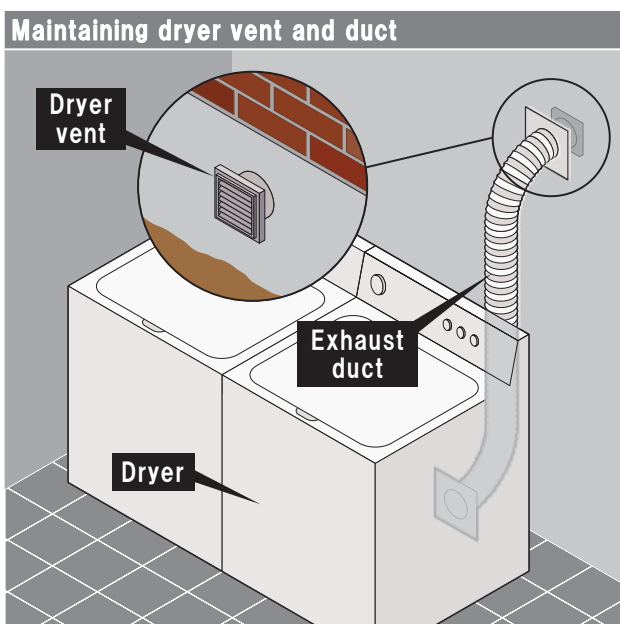

If the dryer vent exits on the roof, have a licensed roofer clean it out.

Garage door

An automatic garage door is a great convenience and probably the largest and heaviest moving object in your home.

Safety is important when anyone is operating the garage door. To keep you and your family safe, it's critical to make sure the door can open properly.

The garage door operates with the help of a spring under high tension. To provide safe, trouble-free operation, it's important to maintain and test the garage door and automatic opener periodically. Also, follow these basic safety rules:

Keep the door in full view and free of obstructions while operating.

Don't allow children to play with or operate the door or electric door controls.

Never stand under or walk through the doorway while the door is moving.

Care and maintenance

If you follow these safety and maintenance instructions, you'll prolong the life of the door, help prevent costly service calls and keep you and your family safe from accidents. To keep your garage door operating efficiently, perform the following maintenance procedures.

To maintain the door

Inspect your garage door and opener at regular intervals for signs of wear and improper alignment.

Check cables, rollers, and hinges for signs of wear every three months. Tighten any loose hinge screws.

Lubricate all hinges, rollers, and moving parts every month with light oil or spray lubricant to reduce noise and add to their life span.

Never lubricate the chain or screw drive. It is lubricated by the manufacturer; aftermarket lubricants can cause it to slip.

If you have a metal door, adding insulating panels to the garage door changes its weight. Call a licensed contractor to adjust the tension of the springs. Also, always remember to lubricate the torsion spring; otherwise, it may lose tension and fail. The appearance of rust on the spring indicates that there isn't enough lubrication.

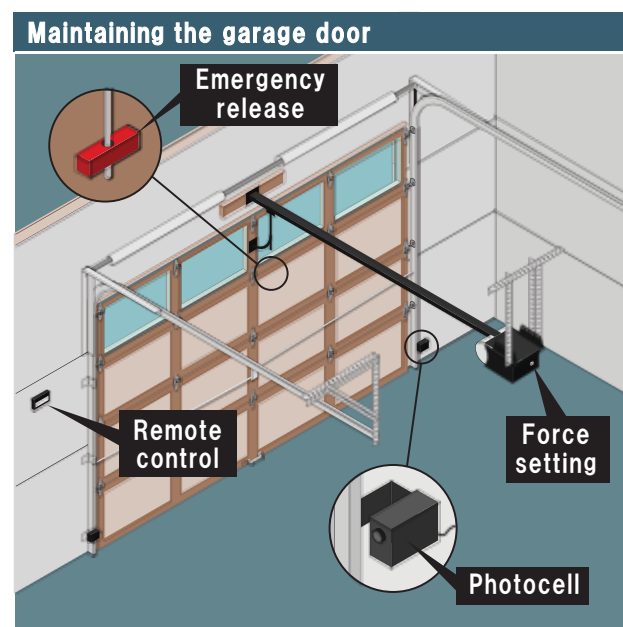

To conduct a balance test

Test the balance of your garage door at least twice a year. It's important to conduct this test because if your door is out of balance, it will strain the opener (the device that opens and closes the door), reducing its life span.

To conduct a balance test, follow these steps:

1. Start the balance test with the garage door closed. Locate the emergency release - a red handle that hangs on the end of a rope. Pull down lightly on the handle to disconnect the door from the opener, so you can operate the door by hand.

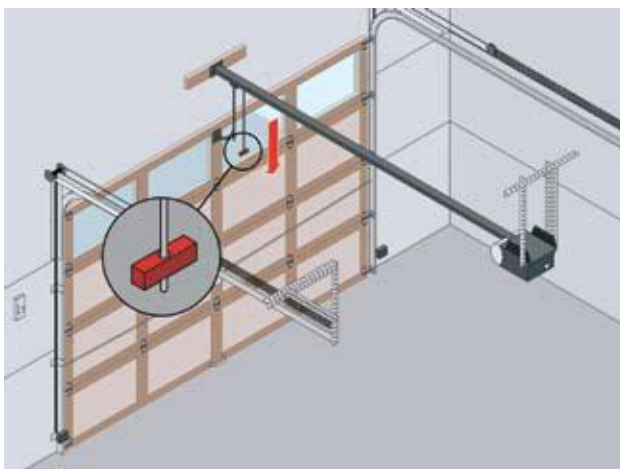

2. Lift the garage door by hand. Do this by standing in front of the door and pulling it upward. The door should work smoothly and with little resistance.

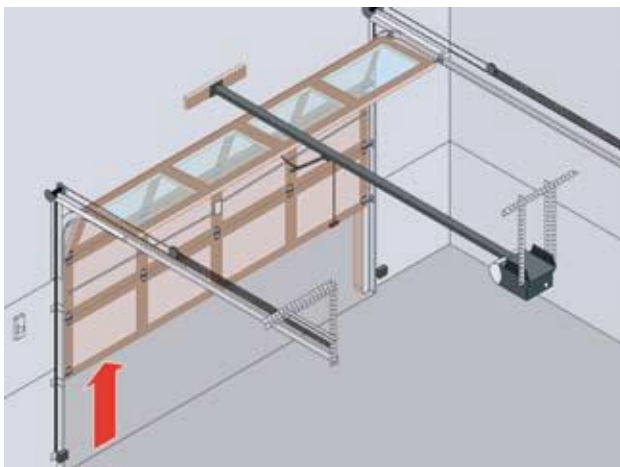

3. Stop lifting the garage door when it's approximately 4 feet from the ground. When you release your hands from the door, it should stay in place. Some slight movement is acceptable. If the door doesn't stay in place, it's likely out of balance and needs to be adjusted by a qualified garage door technician.

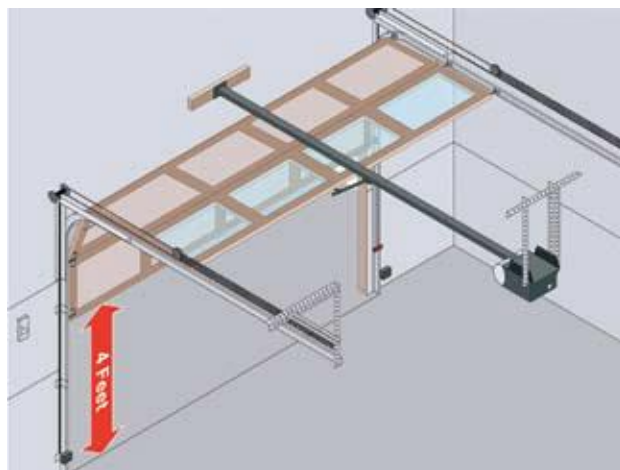

4. Close the garage door by hand. Reset the emergency release by pulling the handle toward the opener power head. Pulling on the handle should reconnect the garage door to the opener.

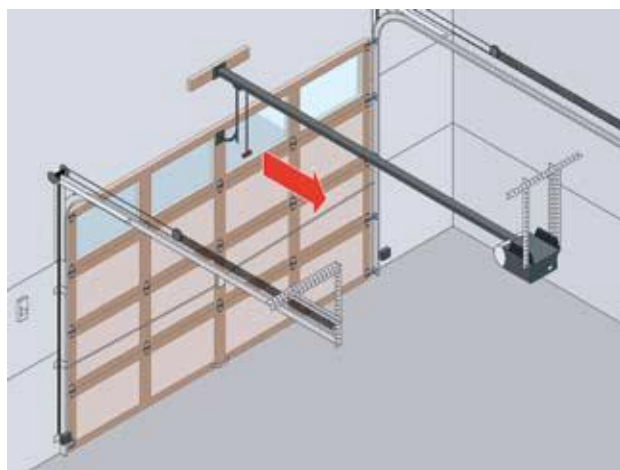

If the door fails to remain in position, call a qualified professional to adjust the spring tension.

To clean the exterior of the door

Clean the exterior surface of the door periodically to keep the buildup of dirt and rust-causing particles to a minimum. Use warm, soapy water to clean the door. Rinse thoroughly.



Don't use harsh cleaners or stiff-bristled brushes to clean the garage door.

To conduct a force setting test

Test the force setting of your garage door monthly. This safety test is used to detect whether or not the force setting is too high. When the force setting is too high, the garage door can close with too much force, potentially causing damage to the door and any people or objects in the way, before reversing direction as it should. Never use a high force setting to compensate for a garage door that's unbalanced or sticking.

To conduct a force setting test, follow these steps:

1. Push the remote-control unit or the wall button to close the garage door. to a minimum.

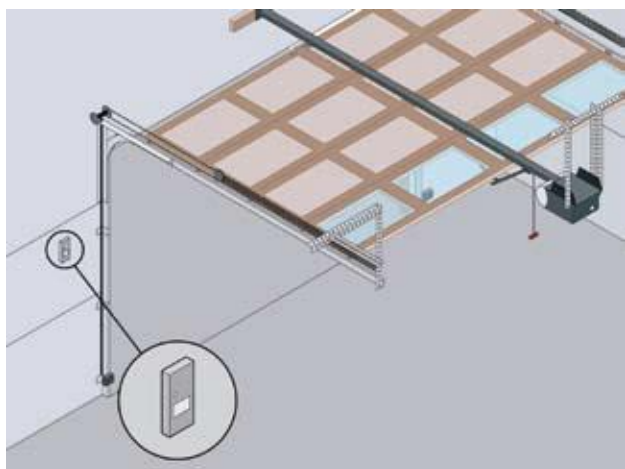

You should be standing near the door when pushing the button in order to do the next step properly. If your wall button isn't near the door, use the remote-control unit instead to close the door.

2. Apply light, upward pressure on the bottom of the door as it closes. The door should readily reverse direction. If the door doesn't readily reverse, the force may be excessive and need adjusting.

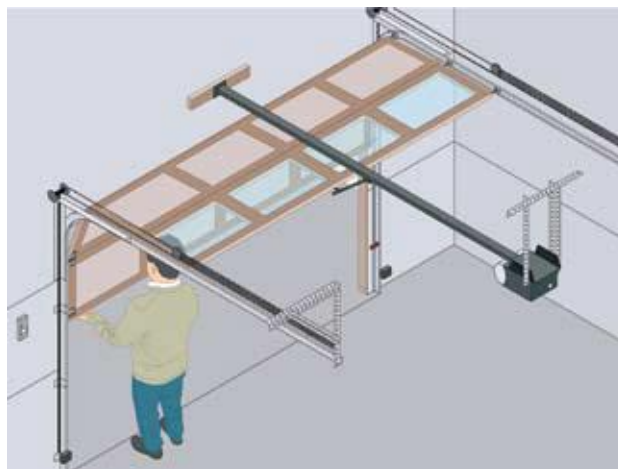

3. Adjust the door's force setting according to the instructions in your garage door owner's manual. The owner's manual provides testing the force setting.



4. Repeat steps 1 and 2 after adjusting the force setting. The door should now readily reverse direction.

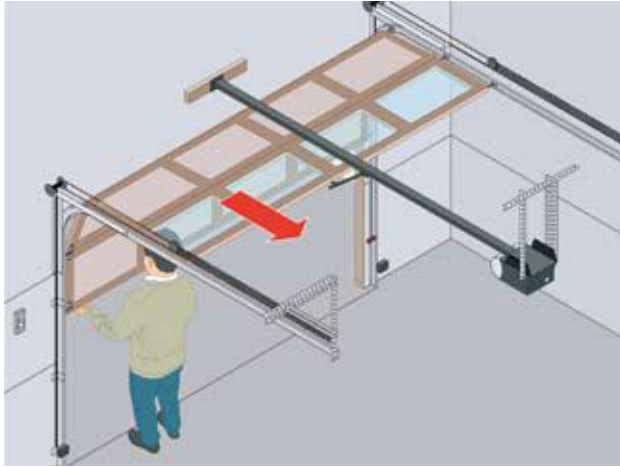

If the door fails to reverse direction, call a qualified professional for service.

To conduct a reversal test

Test the reverse mechanism of your garage door monthly. The reverse mechanism is an important safety feature. When a garage door is closing and comes into contact with a vehicle or other obstruction, the reverse mechanism should cause the door to reverse direction, so it heads up instead of continuing down.

To conduct a reversal test, follow these steps:

1. Start the reversal test with the garage door open. Place a 2x4 wood board flat on the floor at the center of the garage door opening.

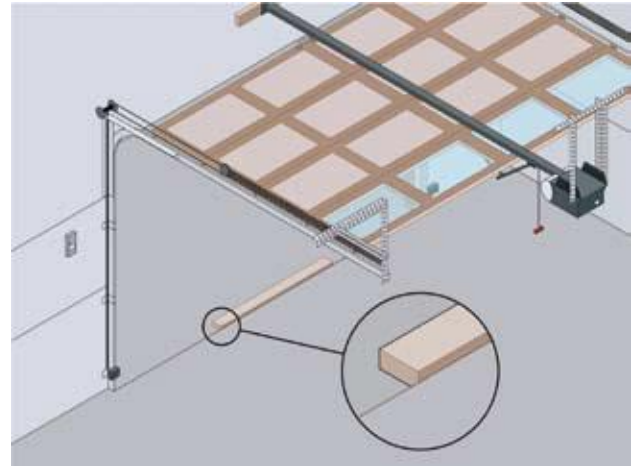

If you don't have a 2x4 wood board handy, use an object 1 1/2 inches high that can withstand contact with a garage door without being damaged.

2. Push the remote-control unit or the wall button to close the door.

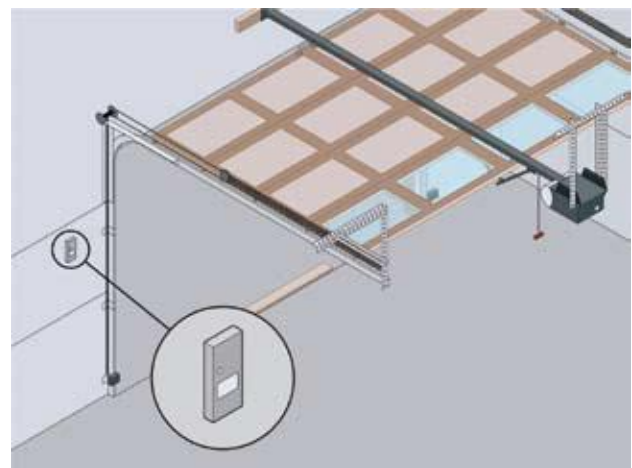

3. Watch the door as it closes. When it comes into contact with the board, it should stop and then reverse direction. If the door doesn't readily reverse direction, one or more parts may need adjusting.

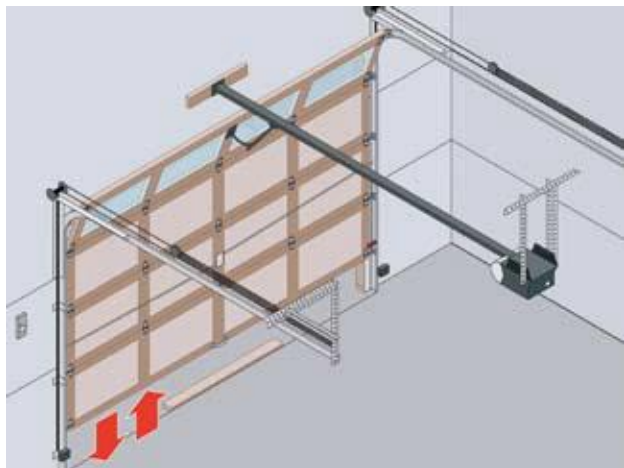

4. Adjust the door according to the instructions in your garage door owner's manual. The owner's manual provides instructions involving a reversal test.

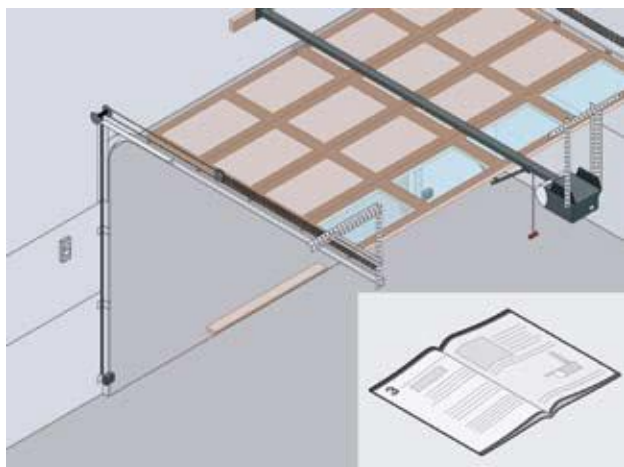

5. Repeat steps 1 and 2 after making adjustments. The door should now readily reverse direction when it comes into contact with the board.

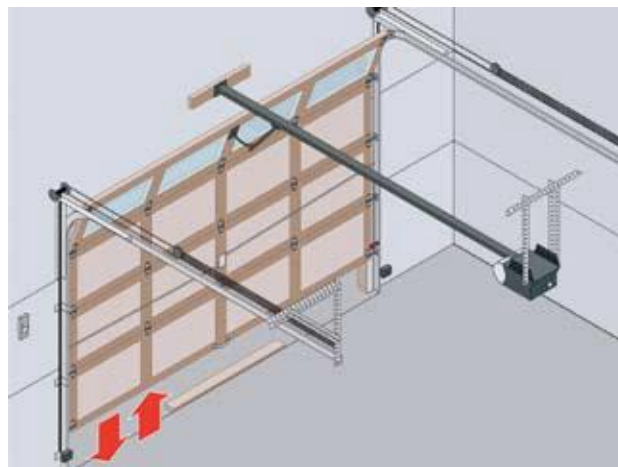

If the door still isn't reversing, call a qualified professional for service. Until then, close the door, disconnect it from the opener (by pulling the red emergency release handle), and discontinue use.

Check the photocells

Check the photocells monthly. They're located on either side of the garage door, 5 inches from the floor, and project a beam of light from one to the other.

If they're working correctly:

One photocell should have a constant red indicator light, and the other should have a constant green indicator light.

If they aren't working correctly:

The red indicator light will be flashing because the beams of light aren't aligned, a wire has been knocked loose, or the beam is blocked. If you try to shut the garage door automatically when the beam is broken, the door will reverse. You can hold down the wall button until the door fully closes, but this won't fix the problem.

Instead, remove all visible dirt or objects, such as leaves or spiderwebs, on the lens of a photocell, which will prevent the system from working. If this doesn't fix the problem, call a qualified professional to make repairs.

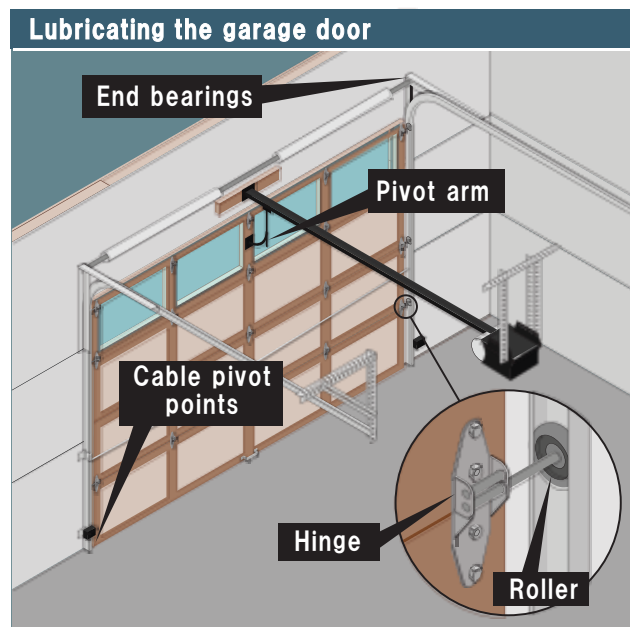

Refer to your garage door owner's manual for more troubleshooting steps.



Don't make repairs to the garage door or the opener. Only a qualified professional should perform repairs.



Don't attempt to make adjustments to the torsion springs, cables, or bottom fixtures connecting the cables to the door. Only a qualified professional with the proper tools and experience should perform repairs or make adjustments to the cables and torsion springs.

Check the batteries in the remote-control units

Check the batteries in the remote-control units annually. When replacing the batteries, check terminals for signs of corrosion.

If your home is part of a Homeowner's Association (HOA)

Check with your HOA regarding maintenance, and be familiar with all HOA documentation.

Gutters and downspouts

Gutters and downspouts help direct water away from your home.

Gutters are troughs that collect water from the roof and carry it toward downspouts. Together, gutters and downspouts direct water off the roof and then down and away from the house. Caring for these elements will extend the life of your roof drainage system by many years.

Make sure the downspouts direct water away from your home's walls and foundation. Downspouts that pour water toward your home can cause water damage to the siding, the foundation, and the basement.



To maintain gutters and downspouts

Inspect the gutters and downspouts on your home at least twice a year, preferably at the start of spring and during the fall. The following guidelines will help you maintain the gutters and downspouts.



Providence has installed ice and water barriers at the front edge of the roof. This helps to minimize the potential for moisture to infiltrate your home from ice damming.

1. Remove all debris from gutters and downspouts as needed. Keeping gutters and downspouts clean will allow water to flow freely. It will also help to prevent the build up of ice in the winter months.

Ice damming can allow moisture to enter your home as the ice builds from the gutter and under the roof shingles. The weight of the ice build up may pull gutters away from roof lines and could cause damage to the gutter system.

Keeping gutters and downspouts clean will also help slow down the deterioration process, a major problem that eventually causes leaks.

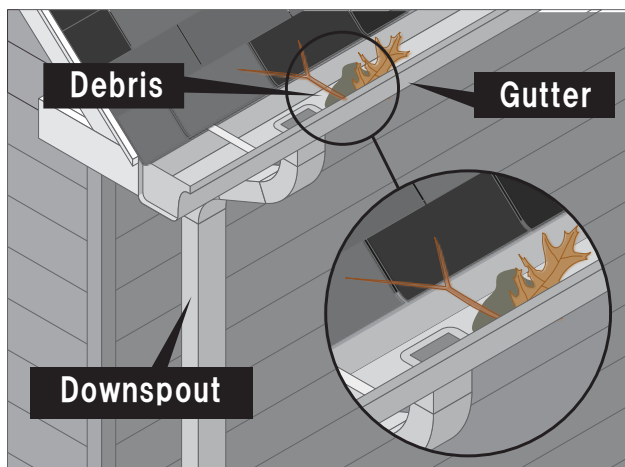

2. Check the elbow where the gutter connects to the downspout. Remove and check the elbow and clear any obstructions.

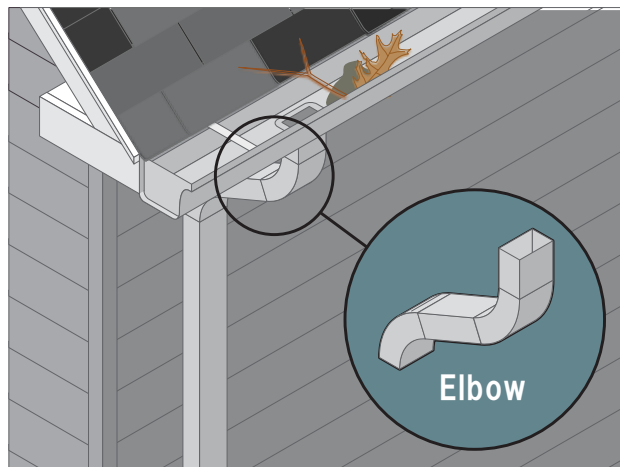

3. Look for the source of any leaks in the gutters and downspouts. Look for cracked caulk at the end caps and between the elbow and the gutter.

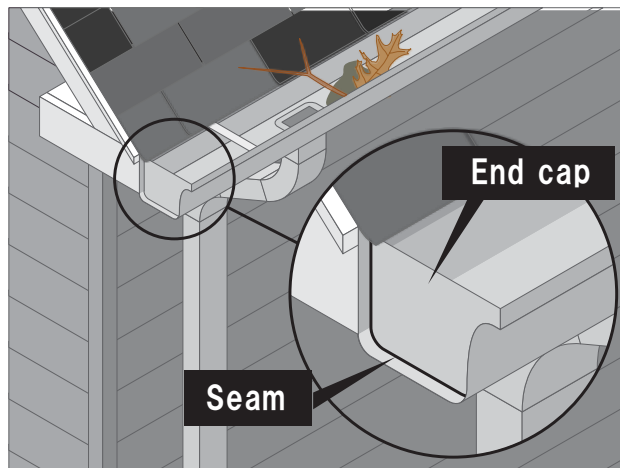

4. Look for cracked caulk at the corners.

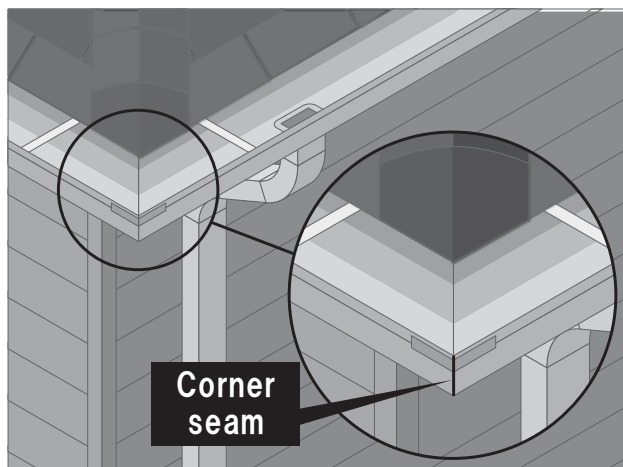

If your home is part of a Homeowner's Association (HOA)

Check with your HOA regarding maintenance and be familiar with all HOA documentation.

Roof

You have a quality roof designed to help protect your home from the elements.

Your roof protects your home from rain, hail, snow, wind, hot sun, and other weather conditions, all of which wear down the roofing materials over time.

The roof requires simple, periodic maintenance. The best times of the year to examine your roof are the spring and fall. A springtime examination, in particular, allows you to check for any winter damage.

Care and maintenance

Follow these care and maintenance suggestions for your home's roof.

Checking the roof

Remain on a ladder instead of stepping onto the roof surface to avoid damaging the roofing materials.

If you have to walk on your roof for any reason, be careful not to damage the surface or the flashings.

Check for the following problems on your roof, and immediately repair, replace, or remove as applicable:

Loose, missing, or damaged shingles.

Curled, buckled, or blistered shingles.

Damaged supports for television antennas or satellite dishes.

Excessive amounts of shingle granules in your gutters. The granules protect the shingles from the sun and give them extra weight.

Overhanging tree branches. Branches can scratch your shingles and can fall and damage your roof structure. Also, leaves on the branches retain moisture, which can cause your roof to rot.

Clogged roof vents.

Damaged flashing. Replace any damaged flashing immediately.

Cracks and leaks in valleys.

Debris in valleys.

Water leaking into the attic on rainy days. If you see evidence of water, locate its source.



If a roof leak occurs, call a qualified roofer to make the repairs. If it's repaired as soon as the roofing material has dried, the cost will be far less than if the job is postponed.



A qualified roofer should inspect your roof at least once every three years.

If your home is part of a Homeowner's Association (HOA)

Check with your HOA regarding maintenance, and be familiar with all HOA documentation.

For more information about roofing materials, visit the manufacturer's website.

Screens

The screens on your exterior windows and doors are constructed of quality material.

Screens, which consist of a woven mesh stretched across a frame, allow the outdoor air in while helping to prevent insects from entering your home. The screens on your home will never need paint or other preservatives.

Care and maintenance

Follow these care and maintenance suggestions for your home's screens.

General maintenance

Keep the screens clean to help keep dirt from being transferred to the exterior siding. Gently wash and hose the screens about once a year.

Remove the screens periodically to clean out the dirt buildup on the sills. A buildup of dirt can trap water on the sills, which may eventually lead to water damage.



It's unnecessary to remove window screens in the winter.



Replacement screen fabric is available from hardware stores.

To replace screen mesh:

1. Remove the splines that are holding the old screen fabric in place by prying them out with a screwdriver that's slightly smaller than the splines.
2. Cut new screen fabric the same size as the outside of the frame.
3. Use the convex edge of a spline tool to push the new screen fabric's edges into the channel on the top and on one side of the frame.
4. Use the spline tool to roll the remaining two edges of new screen fabric into the channel.
5. Use the concave edge of the spline tool to push the splines back into the channel. Pull the screen fabric taut as you do this.
6. Trim off any excess screen fabric with a utility knife.

See also *Windows*.

If your home is part of a Homeowner's Association (HOA)

Check with your HOA regarding maintenance, and be familiar with all HOA documentation.

Siding

The siding on the exterior of your home increases curb appeal and is easy to maintain.

Your home has either vinyl or composite Siding - two types of siding that resemble wood in appearance. Both exterior materials are attractive, durable, and low maintenance. Vinyl is made of polyvinyl chloride (PVC), while composite siding is a combination of wood or cement fibers.

Care and maintenance

Follow these care and maintenance suggestions for your home's siding.

General maintenance

Follow these maintenance suggestions for your home's siding:

Keep sprinklers and other forms of forced water away from siding.

Make sure your gutters and downspouts work properly, so water is directed away from the siding. Downspouts should pour water away from your home.

Make sure there's a 6-inch vertical space between the bottom of your siding and the ground. This space prevents siding from absorbing water from the ground.

Make sure plants are placed at least 2 feet away from the siding.

Keep hot items, such as grills, away from vinyl siding. The heat can permanently damage the siding.

Clean all types of siding with clear water from a garden hose and a soft-bristled, long-handled car brush. Don't scrub too hard.

Remove difficult dirt, mold, and algae using the siding manufacturer's recommended cleaning products, and follow the instructions for cleaning.

Inspect wood siding for evidence of problems like termites, cracks, rot, and water damage.

Check around the exterior of your home for separated or deteriorated caulk approximately one to two times per year.

Check caulk annually

Check the caulk in the following areas:

Where the siding meets the corner board.

At window and door trim.

At brick to wood and brick to siding transitions

Around pipes and vent pipes coming through the siding.

At J-channels (on vinyl siding) around windows and doors.

If you see any separation or deterioration of caulk, remove the caulk and reapply, as necessary.

See also [Exterior caulking](#).

If your home is part of a Homeowner's Association (HOA)

Check with your HOA regarding maintenance and be familiar with all HOA documentation.

For more information about siding, visit the manufacturer's website.

Windows

Inspect, clean, and lubricate your windows, frames, and window hardware annually.

Care and maintenance

Follow these care and maintenance suggestions for your home's windows.

To maintain the windows

Check all hardware on the window. Check the opening and closing mechanism, including the hinges, locking mechanism, jambs, and sliders. Make sure screws are tight and that the rest of the hardware, such as the locks, operates smoothly.

Inspect the weatherstripping to make sure it's effective.

Check the condition of the gaskets holding the glass.

To maintain the window weep holes

Window weep holes channel water to the exterior of your home. They can become clogged by dust and bugs, making regular maintenance necessary.

Follow these suggestions to maintain the weep holes:

Vacuum or dust window tracks monthly to keep them free of dirt and debris. Spray silicone on the track after cleaning. Roll the window back and forth to lubricate the rollers.

Don't put cotton balls in the window track, as they can restrict the flow of water to the exterior of your home.

Clearing the weep holes

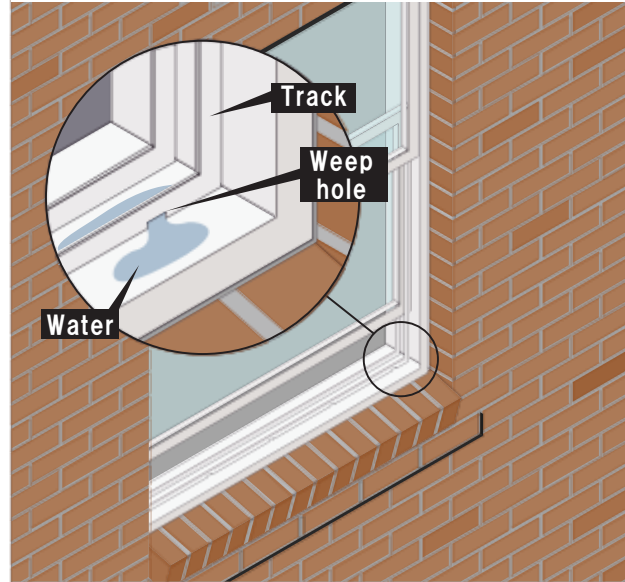

To clean the glass

If the outside of the glass is lightly soiled

1. Clean with a solution of 1 cup of vinegar to 1 gallon of water. Apply this solution with a lint-free cloth or sponge.
2. Dry the glass with a chamois, lint-free cloth, or paper towel.
3. Use a rubber squeegee to speed the drying process.

If the outside of the glass is extremely dirty

1. Wipe it with a piece of crumpled newspaper.
2. Wash it with a solution of 1 tablespoon of household ammonia (or 3 tablespoons of denatured alcohol) to 1 quart of warm water, or use a commercial glass cleaner containing ammonia.



Prevent condensation from forming on the inside of windows. In most cases, you can control the problem by reducing the humidity level in your home.



Don't use a metal scraper to clean the glass. A scraper may scratch your window.

To maintain the window frames

Vinyl Windows

Wash the frames with only a mild, nonabrasive cleaner and water. Never use abrasive or acidic cleaners. Before using any cleaner, test it in an inconspicuous area of the frame. Dry window frames after cleaning them.

To maintain the seal around the window frame

If the seal around the window frame breaks, call the manufacturer for repair.

To maintain the seal, see *Exterior caulking*.

For more information about windows, visit the manufacturer's website.

If your home is part of a Homeowner's Association (HOA)

Check with your HOA regarding maintenance, and be familiar with all HOA documentation.

KITCHEN

Cabinets

Your home has attractive, high-quality cabinets that are designed to meet your needs for functional storage.

Wood cabinets

In wood cabinetry, the grains and color of the wood vary, lending a unique beauty to each piece. Your cabinet doors have been stained and varnished to protect the surface from household chemicals and other agents, as well as to enhance the natural artistry of the wood grain.

Care and maintenance

Follow these care and maintenance suggestions for your home's countertops.

General maintenance

Check the caulking around sinks and backsplashes to prevent water damage to the cabinets.

Use silicone spray lubricant periodically on drawers and hinges to improve operation.

Wash and polish the cabinets once or twice a year. Use a light coat of high-quality furniture polish.

Clean spills immediately. Use a clean cloth and soapy water. Wipe the cabinets dry after cleaning.

Avoid excessive moisture on wood cabinets.

Use a mild soap and warm water to clean cabinet hardware, such as doorknobs and drawer pulls. Dry hardware with a soft cloth.

Don't use detergents, soap pads, steel wool, paste wax, or polishes that contain silicone on your wood cabinets.



Furniture polish can hide minor nicks and scratches that occur over time on wood cabinetry.



If a cabinet door doesn't close flush with the cabinet face frame, either the hinge has twisted, or the door has warped. See your owner's manual on how to adjust the hinge. See your warped door policy on how to repair the door.

For more information about cabinets, visit the manufacturer's website.

Countertops

The countertops in both the kitchen and the bathroom offer you good looks and service for many years.

Kitchen countertops

The majority of kitchen countertops in your new home are constructed from top-quality plastic laminate materials. These products consist of a sheet of very hard plastic laminated to a wooden base. With proper care, they will last for years.

Bathroom countertops

Your bath vanity tops, and perhaps your bath sinks, are made of a top-quality cultured marble product that will give you classic good looks and utilitarian service, with proper care.

Care and maintenance

Follow these care and maintenance suggestions for your home's countertops.

To clean countertops

Wipe off spots, glass rings, and other spills with a damp cloth and mild soap.

Be careful with the inks used in making grocery products, especially meat and produce, as well as newspaper ink; these inks are often indelible.

To prevent damage to countertops

Be especially careful with razor blades, manicure equipment, and bathroom appliances to avoid damaging the laminate.

Prevent damage from leaks by monitoring the condition of all caulking on countertops and vanity tops. Reapply the caulking if it separates or shrinks.

Don't cut items directly on the countertop. Scratches and knife marks can be unsightly hiding places for dirt.

Don't sit or stand on countertops. Excessive weight can cause cracking, warping and drawer malfunction, and can even cause the top to pull away from the wall.



Cigarette burns are almost impossible to remove without professional assistance.

See also *Interior caulking*.

Granite countertops

Granite countertops are made from natural rock. These countertops vary in color and veining. Stone countertops can be scratched. Grainy materials, such as sand and abrasive cleaners, wear down the finish. Improper maintenance also will compromise the look and longevity of your countertops. Stone countertops absorb stains in as little as one minute. A small rock can scratch the surface severely.

You can clean stone countertops with any high-quality, nonabrasive bathroom cleanser. To clean stone countertops:

Remove hard water minerals with a mild ammonia solution of 1 tablespoon to 1 quart of water. Also, commercial cultured marble cleaning and protecting products are available.

Dust or sweep the countertop regularly.

Wipe up spills immediately.

Clean the surface with a few drops of neutral cleaner or stone soap and warm water after each use.

HOMEOWNER TIP *Repair chips, scratches, burns, and stains using the manufacturer's recommended techniques, or consult a professional.*

HOMEOWNER TIP *It's strongly recommended that you have your stone countertops sealed to prevent staining.*

CAUTION *Don't place hot pans or pots directly on the countertops. Use coasters and mats under objects that may scratch the surface.*

CAUTION *Don't use steel wool, vinegar, polish, or liquids containing acid on the surface.*

Solid surface countertops

Solid surface countertops, such as Quartz or Corian®*, are nonporous, homogeneous, and inherently hygienic surfaces. Following these basic guidelines will help to keep these surfaces fresh and looking new.

**Corian® is a registered trademark of the DuPont Company.*

Clean solid-surface countertops with any household cleanser designed for daily use.

Remove typical stains with soapy water or ammonia-based cleansers.

Don't place hot pans or heat-generating appliances directly on the countertop. Use a trivet or hot pad with rubber feet.

Run cold water into the sink if you're going to be pouring boiling water into it.

Avoid prolonged exposure to strong chemicals, such as concentrated acids, and chlorinated solvents, such as chloroform. Also, avoid exposure to acetones, which are found in nail polish remover and paintbrush cleaner. If these chemicals contact the surface, flush the surface thoroughly with soapy water.

Use denatured alcohol to remove stains caused by cosmetics. Flush the surface with soapy water when the stains are gone.

Don't use abrasive pads; they'll scratch or dull the polished finish.

HOMEOWNER TIP *A licensed contractor can polish Corian® to remove some stains, burns, and scratches.*

Dishwasher

With proper use and maintenance, the dishwasher in your kitchen will clean dishes effectively and conveniently.

Care and maintenance

Follow these care and maintenance suggestions for your home's dishwasher.

To clean dishes effectively

Run the disposal before turning on the dish-washer. A clogged sink drain will cause a flood.

Use only dishwasher detergent and only in the recommended amounts.

CAUTION  *If the dishwasher isn't directly wired, plug it into a grounded outlet only. Don't use an extension cord.*

To clean the dishwasher

Some parts of the dishwasher need cleaning.

Clean the control panel with a damp cloth. Dry it thoroughly.

Never use harsh abrasives to clean the dishwasher.

Clean the strainer, pump, and spray arms every three months per the manufacturer's instructions to remove objects that could clog the drain system.

Clean the dishwasher float periodically to prevent it from sticking; it controls the water level in the dishwasher. Follow the manufacturer's instructions to clean the float.

CAUTION  *Before cleaning the interior of the dishwasher, wait at least 20 minutes after a cycle for the heating element to cool down. Failure to do so could result in burn injuries.*

To remove stains

Clean the stain with dishwasher detergent and water. If the iron in your water stains the dishwasher, clean the stains with a commercial soluble rust remover that's safe for use in dishwashers.

To check for leaks

Inspect the dishwasher for leaks every six months. After washing a load of dishes, look along the front and underneath the dishwasher for water leaks.

HOMEOWNER TIP  *Use only automatic dishwasher detergents. The wrong detergent can cause the dishwasher to leak.*

SERVICE TIP  *Call a professional to have any leaks or clogs repaired immediately.*

For more information about dishwashers, visit the manufacturer's website.

Disposal

The food disposal unit in the kitchen helps make cooking and cleaning easier.

Care and maintenance

Follow these care and maintenance suggestions for the disposal in your home.

To use the disposal correctly

Run the cold water, and then turn the disposal on before depositing food into it. Don't deposit foods into an inactivated disposal and then turn the unit on.

Run cold water while the disposal is running. Running cold water helps to solidify any grease in the disposal so it can be chopped up and moved out with the remainder of the foods.

Insert foods loosely into the disposal. If you pack in too much at once, you can jam the disposal.

Keep the disposal running for at least 15 seconds after the noise of grinding has stopped to flush all food particles through the drain line.

Make sure all small objects are removed from the sudsy water before you drain the sink.

If you have a continuous-feed disposal

Move silverware and other small items away from the edge of the sink to avoid accidentally knocking them in while the disposal is running.

To use the disposal safely

With a continuous-feed model, use the cover as directed to protect yourself when grinding bones or fruit pits—the force of the disposal action could eject small particles. Avoid leaning over the disposal if you are feeding waste into it while it is running.

To avoid damage to the motor, all disposals have overload protectors. If the disposal should stall, turn off the disposal and the cold water. Retrieve the article causing the problem. Press the reset button on the disposal. If it won't stay in, wait a few minutes and try again. If the disposal won't start when you turn the switch on, check your electrical panel box for a tripped circuit breaker, and reset as necessary.

What you can't put into the disposal

Follow the directions in the manufacturer's manual regarding what shouldn't be put through the disposal.

Don't grind large bones or fibrous materials, such as corn husks, artichokes, etc.

Don't pour grease or fat down the disposal.

HOMEOWNER TIP *Pour liquid fat into a jar or can, and then solidify it in the refrigerator. Dispose of the jar or can in the trash.*

CAUTION

Never put your hands inside the disposal unit. If you drop something down the disposal unit, use long-handled tongs to retrieve it.

To clean the inside of the disposal

Disposals may emit odors when food particles and grease collect in the grind chamber and on the baffle. This odor can be unpleasant and is typically the result of not running enough water during and after using the unit.

Clean the inside of the disposal by doing the following:

1. Unplug the disposal or disconnect it from the power supply by switching off its circuit breaker.

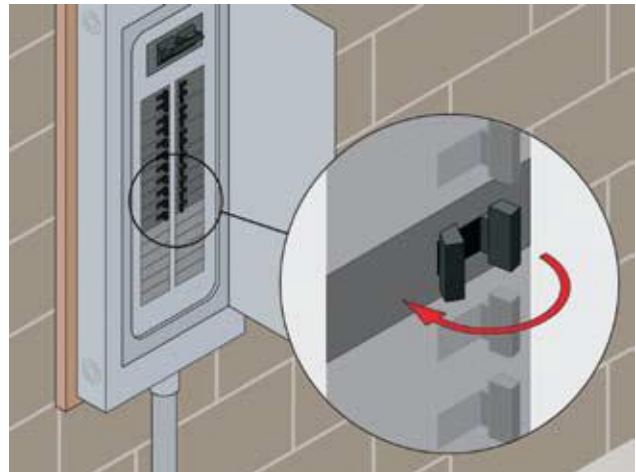

2. Use a scouring pad to clean the inside upper lip of the grind chamber and the underside of the splash baffle.

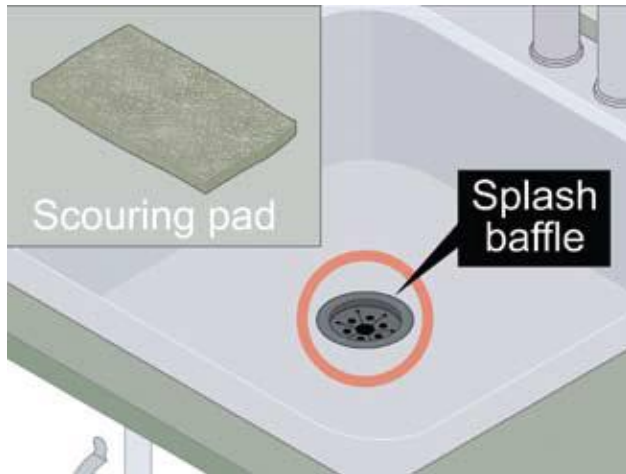

3. Stop up the sink and fill it halfway with warm water.

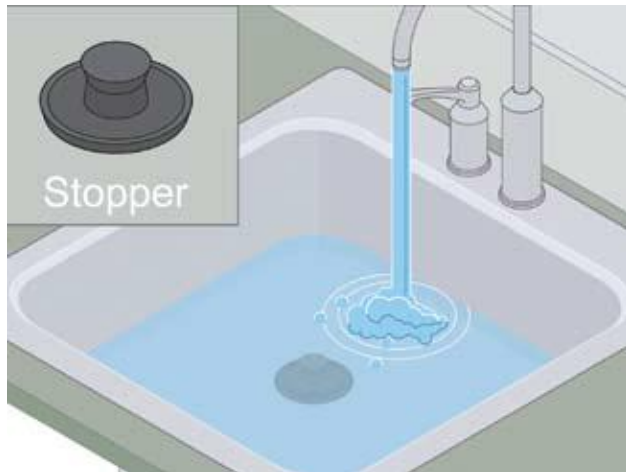

4. Pour 1/4 cup of baking soda into the water and mix.

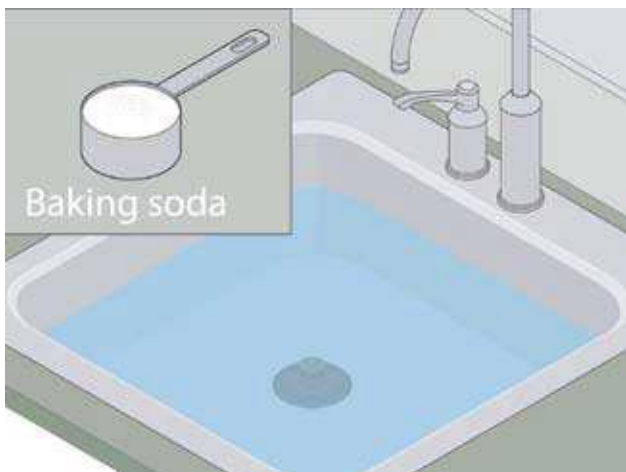

5. Plug in the disposal or reconnect it to the power supply by switching on its circuit breaker.

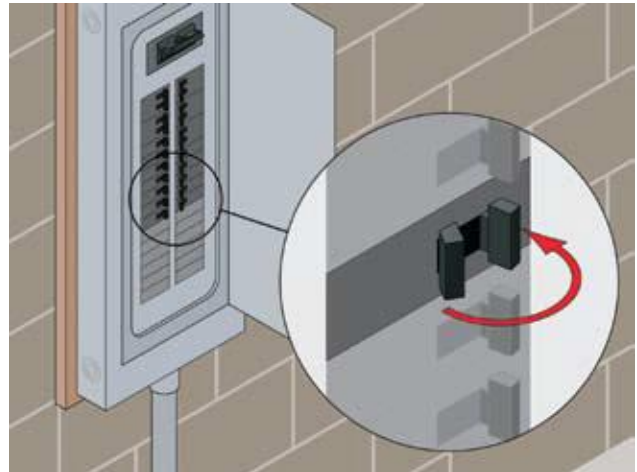

6. Turn on the disposal and remove the stopper from the sink at the same time to wash away loose particles



To clear a jam in the disposal

A jam is when the disposal's motor stops while the disposal is running. Disposal manufacturers provide model-specific instructions on how to clear a jam, as well as how to keep one from occurring.

In general, to clear a jam in the disposal, follow these steps:

1. Turn the disposal's power switch to the OFF position. Taking this step is essential in ensuring your safety while clearing a jam. If water is in the sink, wait for it to drain or bail it out.



2. Locate a hex wrench. Many disposal manufacturers automatically supply a hex wrench with the disposal. A hex wrench is a simple tool that's also available for purchase at home care centers.

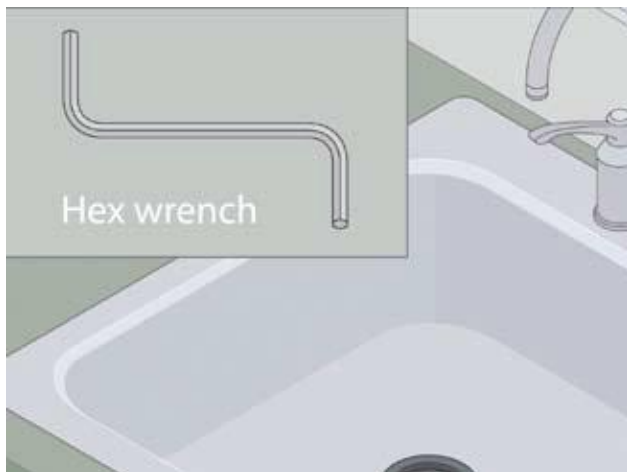

3. Look on the bottom of the disposal for a hexagonal-shaped hole. Insert the hex wrench into the hole. Work the hex wrench back and forth until it turns a full rotation in both directions.

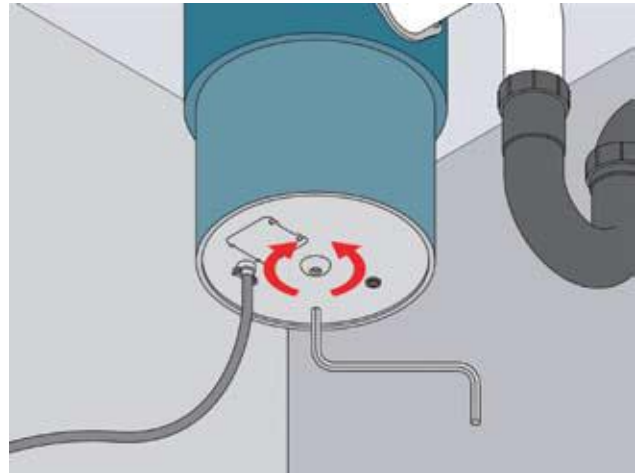

4. Look into the disposal's grinding chamber using a flashlight. You can see the grinding chamber by peering down the sink's drain. Use long-handled tongs to remove any objects from the disposal.

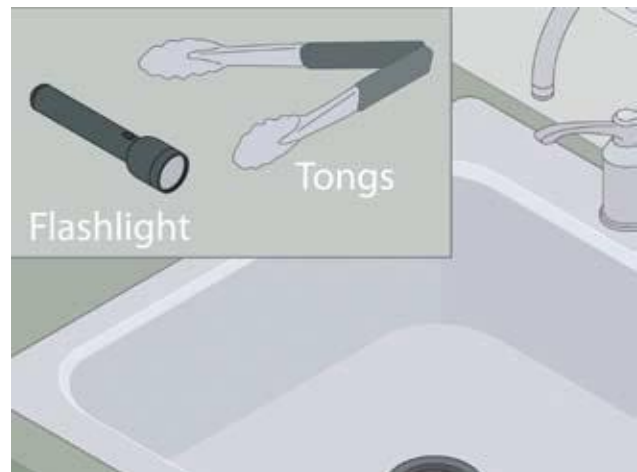

CAUTION ▶ *Never put your hands inside the disposal unit.*

5. Allow the disposal's motor to cool for three to five minutes.



6. Push the red reset button on the bottom of the disposal. If the button won't stay in, wait a few minutes and try again. If the disposal still fails to work, check your circuit breaker panel for a tripped circuit breaker and reset it.

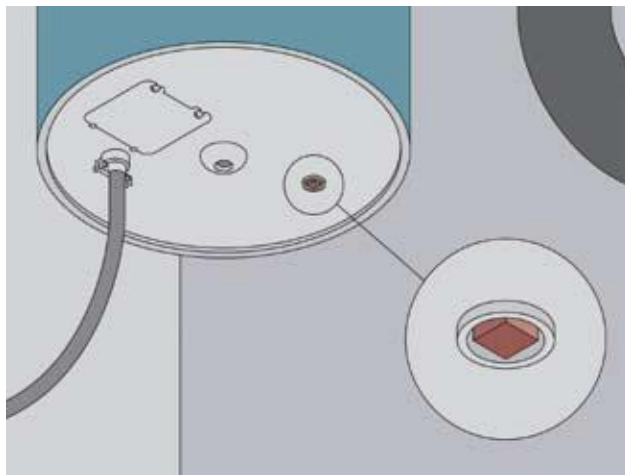

HOMEOWNER TIP *If your disposal is designed to plug into an outlet instead of being directly wired, make sure it's plugged into the right outlet.*

7. Run a steady to strong flow of cold water from the faucet, and then turn the disposal's power switch to the ON position. The disposal should now work properly. If it jams again, repeat steps 1 through 7.



SERVICE TIP *If you can't clear a jam in the disposal, call a licensed plumber for assistance.*

See also *Circuit breakers and Electrical troubleshooting.*

For more information about disposals, visit the manufacturer's website.

Ranges, cooktops, and ovens

Refer to the warranty and care and maintenance information that was supplied with your appliances.

LANDSCAPING

Driveways, walks, and patios

Driveways are made from asphalt or concrete; walks and patios are made from concrete. They require minimal but consistent maintenance.

Care and maintenance

Follow these care and maintenance suggestions for your home's driveways, walks, and patios.

Asphalt driveways

Apply a sealcoat mixture every year to protect the surface, fill in crevices, maintain the appearance of your driveway, and help keep water from penetrating and deteriorating the asphalt.

Keep the driveway free from gasoline and motor oil. This will help prevent deterioration of the driveway.

Fill any cracks with asphalt filler as soon as they show.



Never park bicycles or set outdoor furniture on asphalt. The sharp ends of a kickstand or chair legs can put holes in the asphalt.

Concrete driveways, walks and patios

Many driveways, walks and patios are constructed from concrete. All concrete structures crack slightly as they expand and contract. Control joints have been provided in your driveways, walks and patios to minimize this cracking characteristic. **However, all concrete driveways, walks and patios develop small cracks.**

Concrete is a blend of Portland cement, silica sand, and specially formulated resins. The following recommendations will help you maintain a long-lasting concrete surface.

To clean the surface

Wash the entire surface on a weekly basis to remove surface contaminants such as dirt, salt, and other airborne particles. Don't use more than a garden hose and water. Check with your local water authority first to make sure you are allowed to wash these surfaces.

Clean the entire surface using a household detergent once a month, if necessary. Rinse thoroughly.

To maintain the surface

Use plastic, fiberglass, or rubber-coated patio furniture to reduce damage to the surface treatment. Steel furniture can damage the coating.

Touch up any damage to the coating right away with a 100 percent acrylic topcoat stain. Immediately rinse away any acidic materials spilled on the surface using plain water.

Seal your concrete surfaces with a good-quality sealer annually to protect the surface and the finish from water, road salt, and oil stains.



Improper use of a power washer can damage concrete coatings and finishes.



Avoid contact with acids or acidic materials.



Don't apply salt to concrete or asphalt; salt deteriorates the surface of these materials. Use sand instead to provide traction in slippery conditions. Use floor mats near exterior doors to keep sand from being tracked into your home.

To fill small cracks in concrete flatwork

Concrete flatwork can develop small cracks 1/8- to 1/2-inch wide in cases of severe frost or changes in the grade around your home. These cracks are ordinarily of no serious consequence; they just detract from the appearance of your flatwork. However, small cracks can potentially lead to real problems down the road if left unsealed. Prevent them from becoming a costly repair by inspecting concrete flatwork in early spring and applying a concrete crack sealer to any small cracks. Concrete crack sealer is easy to apply and readily available at any home care center.

To repair small cracks in concrete flatwork, follow these steps:

1. Roughen any edges of the crack that are smooth using a tool like a wire brush or cold chisel.



2. Clean out any dirt, organic matter, or concrete chips from the crack using a tool like a masonry brush, heavy paintbrush, or shop vacuum.



3. Measure the depth of the crack. If it is deeper than 1/2 inch, fill up the crack with sand or backer rod to within 1/4 inch of the surface. If the crack isn't deeper than 1/2 inch, just move on to the next step.



4. Fill the crack with a concrete crack sealer available at any home care center, following the manufacturer's instructions. Overfill the crack slightly to allow for shrinkage.



HOMEOWNER TIP *Apply concrete sealer when the outdoor temperature is between 45°F and 100°F. Also, apply concrete sealer only when rain isn't expected within the next 24 hours.*

If your home is part of a Homeowner's Association (HOA)

Check with your HOA regarding maintenance, and be familiar with all HOA documentation.

Landscaping grade

The grade -the contouring of the land around your home- is designed to provide proper drainage away from your home; it shouldn't be altered in any way that could interfere with drainage.

Landscaping grade

Professional engineers have established the grade of your homesite to provide drainage away from the home and, in some areas, a certain amount of water retention on the site, using a system of berms (high spots) and swales (low spots). It's very important to maintain proper drainage away from the house.

Maintain the drainage slope that was established during the landscaping of your yard. Make sure any changes you make to your landscaping, such as adding a new fence or a swimming pool, don't alter the drainage of your property. In the case of major downpours, expect some water accumulation; however, this water will recede within a reasonable amount of time.



Termites

A proper grade away from the home also helps prevent termite infestation. Subterranean termites usually live in the soil below homes. When there isn't direct contact between the wood framing and the soil, termites build tubes or tunnels to travel from one to the other. The presence of these tubes indicates a termite infestation.

Care and maintenance

Use these care and maintenance suggestions to prevent moisture and termite damage in your home.

To maintain yard drainage

Don't change the drainage pattern on homesites designed for some water retention.

Always maintain a 6-inch minimum vertical space between the earth and any siding. If you don't, water can enter the joint between the footing and the wall material or deteriorate the siding or brick.

Keep drainage ditches and swales free of leaves, debris, plants, and other elements that may interfere with water flow.

Reestablish the original grade of your homesite if the soil settles over time.

Delay any major landscaping projects until your home is at least one year old. Most soil settlement occurs during the first year.

Hire a licensed landscaper to install or modify your landscaping.

Don't plant new plants or grass too close to the house. Watering plants near the house can cause leaks into the interior and other water problems.

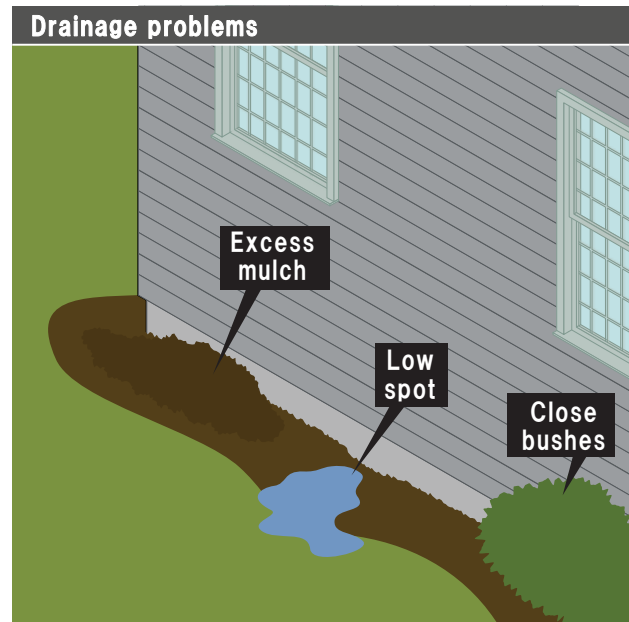

Changing the drainage pattern on your property during landscaping projects could cause serious water problems.



Call your local utility to have buried electrical, gas, water, and telephone lines located before digging in your yard.



Check for termites each year in the spring. Look for the remains of winged insects. Search the sides of the footing walls for the earthen tubes termites build to reach the wood framing above the foundation. Use the blade of a knife to test the wood for soundness. If you suspect that termites are present, consult a professional exterminator.

See also *Gutters and downspouts*

See also *Sprinklers and irrigation.*

If your home is part of a Homeowner's Association (HOA)

Check with your HOA regarding maintenance, and be familiar with all HOA documentation.

Sprinklers and irrigation

Your home's sprinkler and irrigation system will help keep your yard beautiful year-round.

The four main parts of your sprinkler and irrigation system are the sprinkler heads, the supply lines, the valves, and the backflow preventer. Each provides an essential function.

The sprinkler heads are the fixed heads in your landscape that spray water in either a fan-shaped pattern or in rotating streams. The supply lines are the irrigation pipes running beneath your yard from the sprinkler heads to the water source. The valves allow you to shut off the water to your sprinkler and irrigation system. The backflow preventer prevents water within your irrigation system from backing up the pipes and entering your drinking water.

An annual backflow prevention test is required by the state. This test must be conducted by a certified and licensed backflow prevention testing company.

Care and maintenance

Follow these care and maintenance suggestions for your home's sprinkler system.

Be sure to winterize the sprinkler system in the fall. Turn off the timer and drain the water from the pipes.

Failure to winterize the sprinkler system will result in damage to underground pipes, sprinkler heads, and valves.

Restart the sprinkler system in the spring. Turn on the timer and the master valve.

Check for sticking valves.

Inspect for leaks at the connections.

Check for missing or damaged sprinkler heads and emitters.

Flush out the sprinkler system twice a year.



Some areas require adhering to the regular watering schedule determined by the local water authority. Check with your local water authority to make sure you are in compliance.

To prevent water damage to your home

Make sure the sprinklers don't spray the house or the area near the foundation; it could damage the exterior or cause leaks.

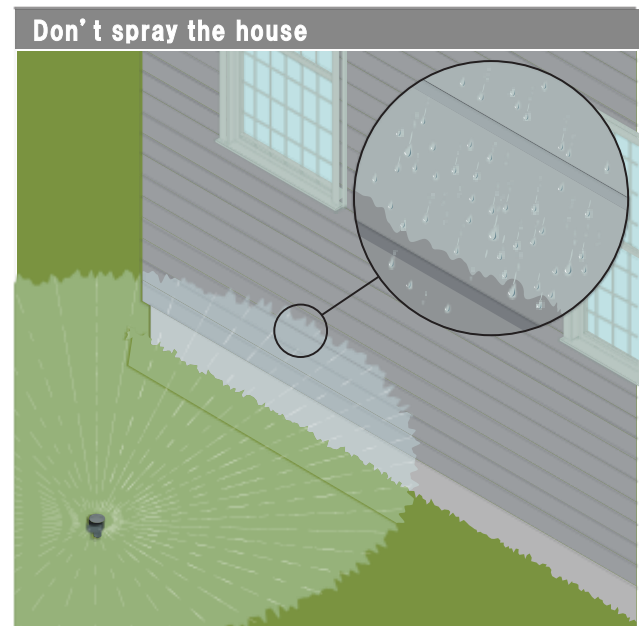

If your home is part of a Homeowner's Association (HOA)

Check with your HOA regarding maintenance, and be familiar with all HOA documentation.

PLUMBING

Drains

All the water you use leaves the home through a drain. Maintaining drains prevents clogging, overflows, water damage, and other problems.

Care and maintenance

Follow these care and maintenance suggestions for your home's drains.

Drain traps

Most plumbing fixtures (e.g.: sink, shower, bathtub, toilet) have a drain trap. A drain trap is a J-shaped piece of pipe beneath the fixture. It holds water that forms a barrier to keep sewer gases in the drainpipe system from entering the home.

To maintain drain traps

If you use a particular plumbing fixture infrequently, turn it on at regular intervals to replace evaporating water in the drain trap and keep the water barrier intact.



Traps, because of their shapes, are the point where drains are most likely to become clogged.

To check appliances for leaks

If an appliance that uses water, such as a dishwasher, appears to be leaking, check the drain before calling for repair. A partially blocked drain can cause overflowing.



Caustic soda is sold commercially as a drain cleaner, but you should never use it to open a drain. It will combine with the grease from soap or food wastes to form an insoluble compound.

To keep drains clear

To keep a drain clear of grease from soap and cooking utensils, add ordinary baking soda to the drain. Follow this preventative procedure regularly to keep the drain clear.

1. Run hot water through the drain, and then turn the water off.
2. Add 3 tablespoons of baking soda.
3. Follow the baking soda with just enough hot water to wash it down the drain opening.
4. Let the baking soda set for 15 minutes, then run more hot water..



Never pour grease into a drain or toilet.

To clear a drain

To clear a clogged drain, plug any overflow outlet with a piece of cloth so the plunger can develop the necessary suction and pressure. For example, if you're clearing a drain for a double sink, plug the other drain. Then, try the following procedures to clear the drain.

Use a plunger

1. Make sure the water comes up well over the edge of the plunger cup.

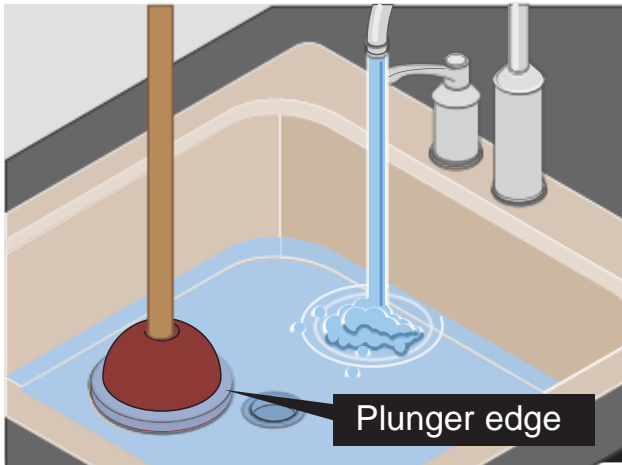

2. Make sure the rubber plunger cup completely covers the drain opening. Work the plunger up and down rhythmically 10 to 20 times in succession to build up pressure in the pipe. This method is more effective than sporadic, separated plunges.

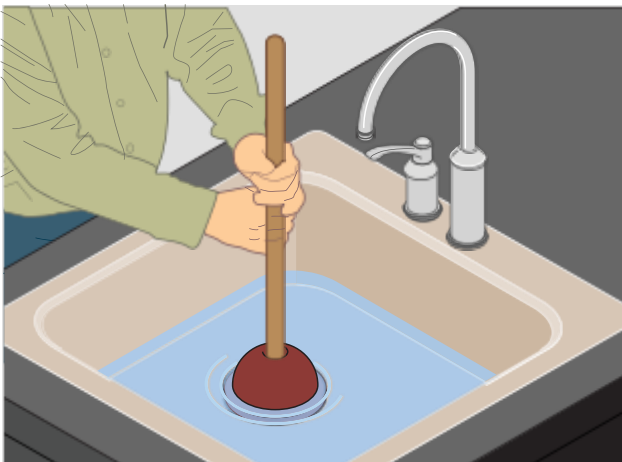

Open the trap

- Opening the trap is a messy last resort for a quick fix, but it will usually solve the problem.

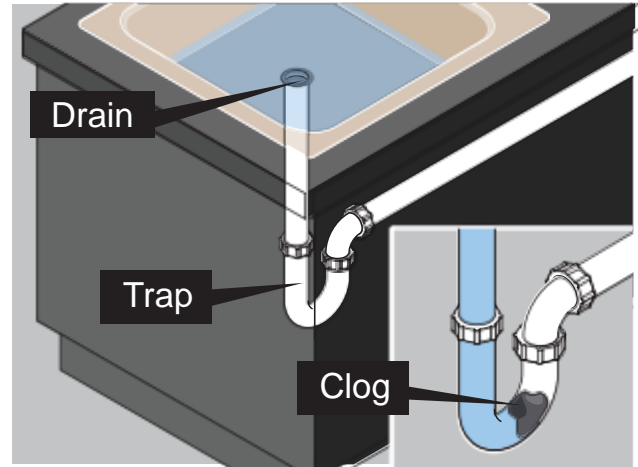

1. Put a bucket or pan under the drain to catch water.

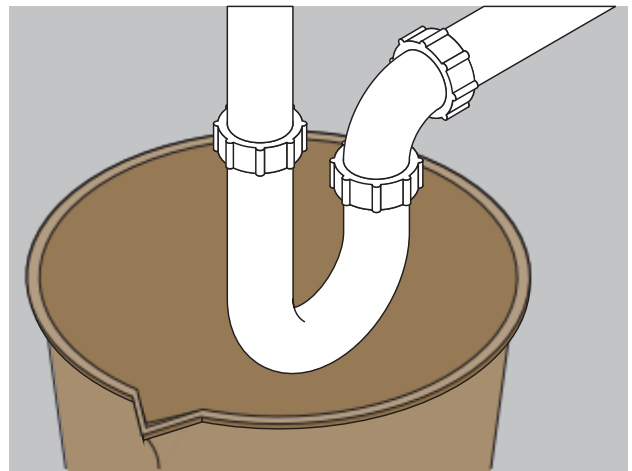

2. Unscrew the two slip nuts holding the trap in place.

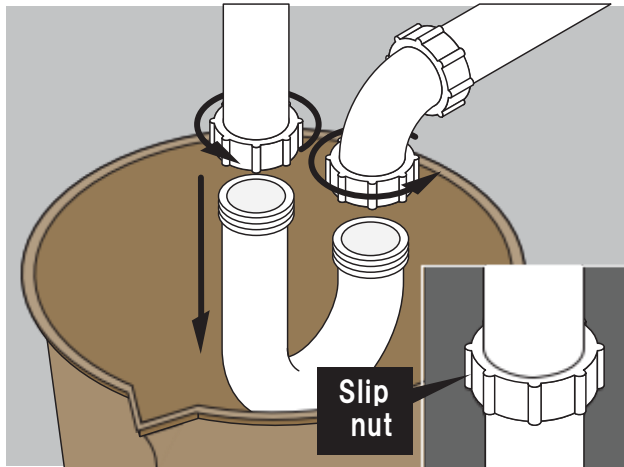

3. Remove the trap and use either a piece of wire or a plumber's snake to dislodge the blockage.

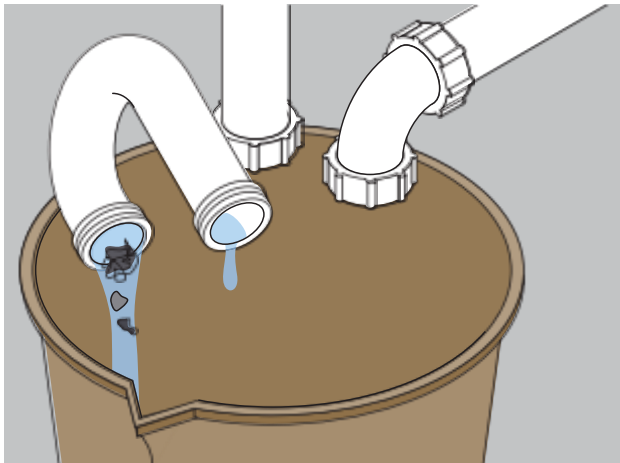

If you feel comfortable using a plumber's snake to unclog a drain, you can rent or purchase a snake at a hardware or plumbing store. Turn the handle of a snake in the same direction when inserting and removing it to keep any matter attached to the snake from coming loose before it can be removed.



If you need assistance to unclog a drain, call an approved professional plumber.

Faucets

Your faucets are designed to look great and perform well for many years.

Faucets

Faucets, like all plumbing fixtures with moving parts, are apt to require more repair than nonmoving fixtures. The less strain you put on your faucets, the less frequently they need repair.

Faucet aerators

Cleaning the aerators will be the most frequent task in maintaining your faucets. A lack of water pressure is usually caused by a buildup of sediment on the aerator screens inside the faucet. Faucet aerators add air to the water as it leaves the faucet, reducing splashing and providing some water conservation.

Care and maintenance

Follow these care and maintenance suggestions for your home's faucets.

Faucet general maintenance

The various types of finishes require different cleaning and maintenance methods. Use the manufacturer's recommended cleaning products and follow the cleaning instructions.

Don't use industrial, abrasive, or tile cleaners to clean faucets.

Don't use any pads or sponges that are unsafe for polished metallic surfaces. Most pads or sponges contain microscopic mineral particles that can scratch a faucet's finish.

Prevent water spotting and mineral buildup by wiping faucets dry after each use.

To clean faucet aerators

Clean the faucet aerators every three or four months or more frequently in areas with high levels of hard water. Follow these guidelines to clean them:

1. Unscrew the aerator from the mouth of the faucet.
2. Remove any debris.
3. Remove and rinse the washer and screen.
4. Replace the parts in their original order.
5. Replace the unit on the faucet mouth.

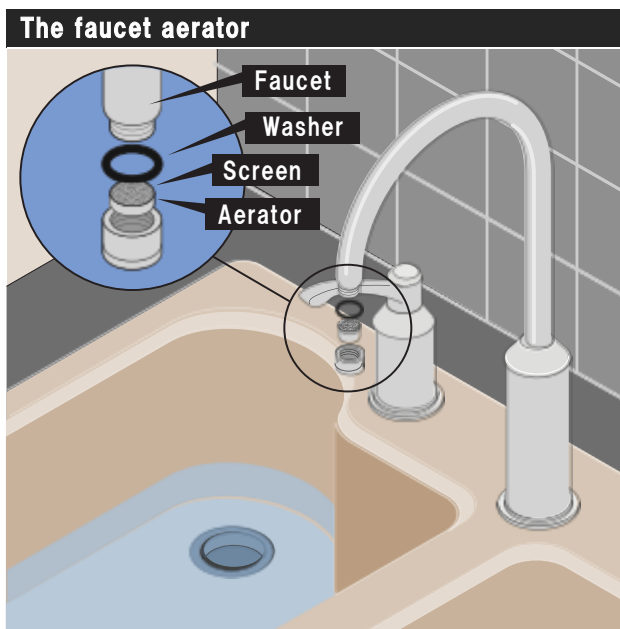

Some faucets require a special tool to access the aerator.

To repair a leaking faucet

Repair a leaking faucet by replacing the washer or cartridge. Use the following guidelines to help.

1. Consult the faucet manufacturer's instructions to purchase a replacement washer or cartridge.
2. Turn the water off at the shutoff valve.
3. Open the faucet handle to relieve the water pressure.
4. Replace the washer or cartridge by following the manufacturer's instructions.

See also *Shutoff valves*.

For more information about faucets, visit the manufacturer's website.

Pipes

The plumbing pipes in your home are designed to function without any maintenance, but if maintenance is needed, it should be performed by a professional plumber.

Care and maintenance

Follow these care and maintenance suggestions for your home's pipes.

General maintenance

Check under your sinks, with the water running, to ensure all connections are tight.

If you discover a leaking or broken pipe

Turn off the main shutoff valve to help prevent water damage and call for service.

If you're disturbed by noisy pipes

Plumbing pipes will make noise at times. It isn't unusual to hear water running through the drainpipes between your walls. Water supply lines sometimes produce a clicking noise as they expand when hot water runs through the pipe, and then contract when the water cools down.



Call for professional service if you hear a loud banging noise when using the water pipes.

If a plumbing joint loosens

Plumbing joints are intended to last the life of the home. If a connection loosens, call for service.

See also *Shutoff valves and Main shutoffs*.

Shutoff valves

Shutoff valves prevent flooding and water damage when water-using fixtures and appliances overflow or leak.

Water shutoff valves work just like their name implies - they allow you to shut off water to particular areas of your home to prevent flooding if a fixture or appliance fails.

The main shutoff valve that cuts off the water supply to the entire home is typically located near the water meter. Most of the water-using fixtures and appliances in your home have their own shutoff valves. The shutoff valves for some fixtures, such as bathtubs and showers, might be difficult to access. It might be easier to cut off the main water supply instead of the individual shutoff for one of these fixtures if needed.

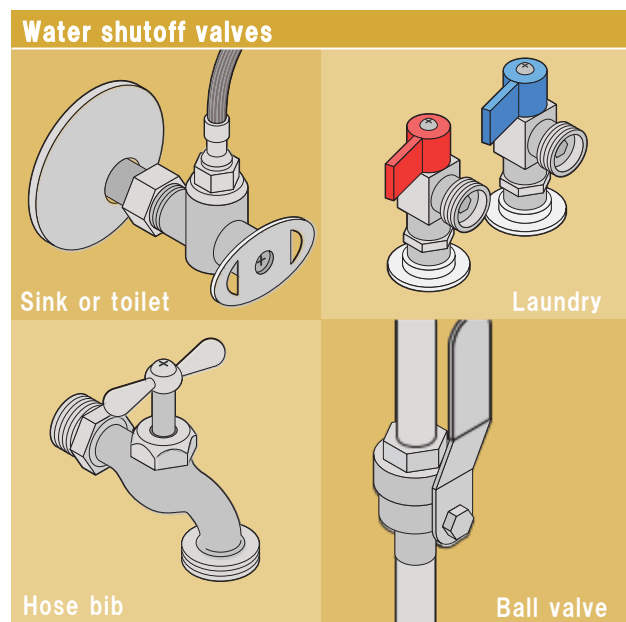

Care and maintenance

Become familiar with the various water supply shutoff valves in your home. A good practice is to label each valve with a tag for easy reference. Know the locations of the water shutoff valves for the following fixtures and appliances:

Sinks

Toilets

Bathtubs

Showers

Dishwashers

Water heaters

Laundry areas

Refrigerators and ice makers

Sprinklers, fire sprinklers, and lawn irrigation systems



Shut off the water supply if you're leaving home for an extended period of time.

Water heater

You have an energy-efficient water heater that, with some maintenance, will provide hot water for many years.

The water heater provides the amount of heated water you'll need during peak usage times. A plastic tube carries incoming cold water into the bottom of the tank, where the water is heated. Hot water rises to the top of the tank. All gas and electric water heaters have a control mechanism to govern water temperature. If your water heater has the capability to set the temperature, set it between 120°F and 130°F.

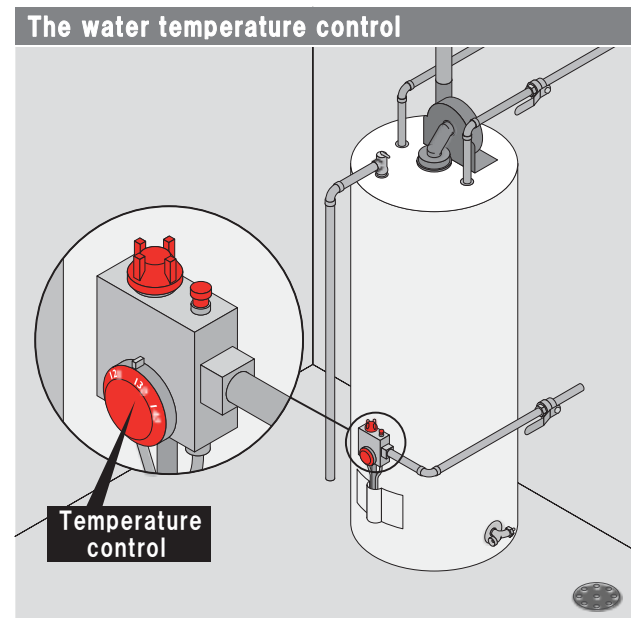

Care and maintenance

Follow these care and maintenance suggestions for your home's water heater.

General maintenance

The water heater is easy to take for granted until it suddenly stops working. Maintenance is easy to overlook because the water heater looks fine from the outside. But inside, two things are constantly attacking your water heater: rust and limestone sediment.

Most steel water heater tanks are lined with glass to prevent rust, but the glass lining isn't perfect, and the constant temperature fluctuations cause it to expand and contract, making small openings. When water eventually penetrates the lining, the tank begins to rust.

At the same time, the heated water causes limestone to form in the tank. As it forms, it settles to the bottom of the tank. In gas water heaters, limestone sediment eventually becomes thick enough at the bottom to reduce heating efficiency. In electric tanks, sediment collects on the heating element, forming a hard crust that eventually makes the heating element stop working.

To keep your water heater operating correctly and minimize rust and limestone buildup, you need to perform regular maintenance.



If you leave home for an extended period, turn off your water heater at the electrical breaker panel; this will protect the heating element and reduce your use of electricity while you are away.

To test the pressure relief valve

Test the relief valve annually to make sure it hasn't become clogged with limestone buildup. You can test the valve while the water tank is full.

1. Make sure the valve is connected to a pipe that directs the water down and away from the tank so that scalding water doesn't spray someone if the valve releases hot water due to excessive pressure.
2. Put a bucket under the drainpipe to catch the water.
3. Open because it the valve by lifting the handle slightly. Use caution because it will release hot water.

See also *Electrical troubleshooting*.

To drain the water heater

To remove sediment, drain the water heater at least once each year. If you haven't drained the sediment on a regular basis, you may need to repeat the process a few times. Make sure you let the water heater fill back up each time before draining it again.

1. Shut off the gas or electricity to the water heater.

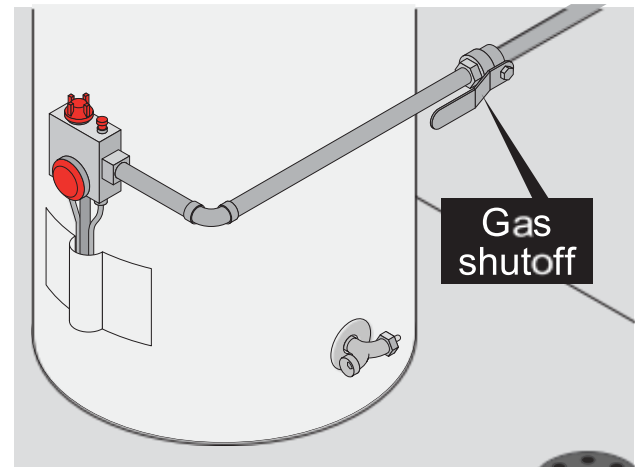

2. Attach a garden hose to the drain valve at the bottom of the tank.

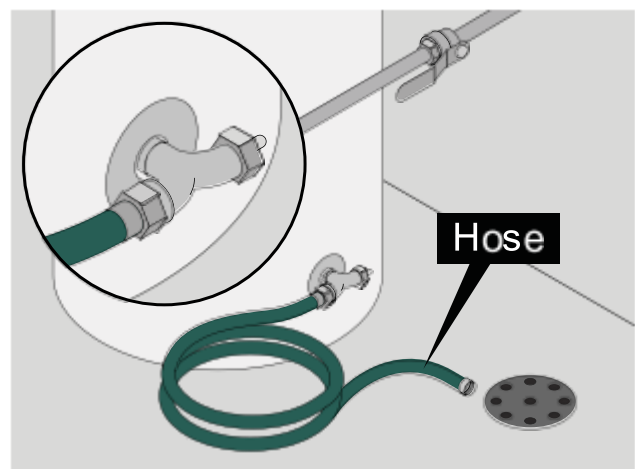

3. Locate the shutoff valve for the water heater
And shut off the water supply for the tank.

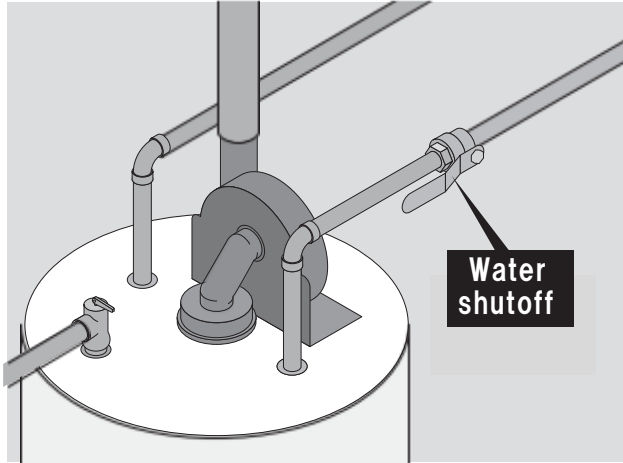

4. Open the pressure relief valve on the tank to
break the vacuum.

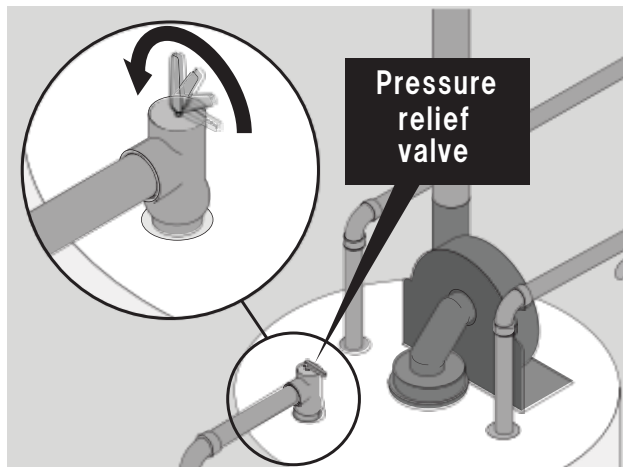

5. Open the drain valve on the tank, and drain
up to 4 gallons of water or until the water
becomes clear.

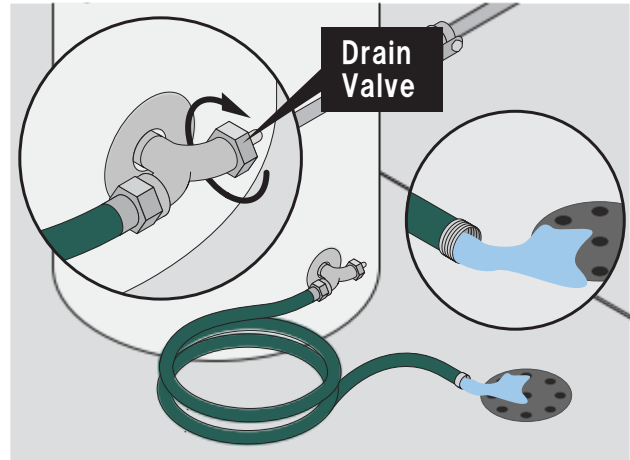

After draining the water heater, disconnect the hose, close the fitting, and turn the water back on. Don't turn the gas or electricity back on until the tank has refilled.



A water softener will help to keep the tank clean.